

Gauge union

Model : A020

Spec. sheet no. AD00-02

Service intended

It is used for positive sealing while the pressure gauge may be directed into any directions.

Standard features

Max. working pressure

Stainless steel : Up to 42 MPa, at 20 °C, G½"

ASME B1.1 Appendix B

Max. working temperature : -10 to 120 °C

※ This product's Max. working temperature could be varied depending on its working pressure and temperature.



Main order

1. Base model

A020 Gauge union

2. Union type

N Pipe welding	R S.W (F)
P PF (M)	S S.W (M)
Q PT (M)	T Flange

3. Material

C 304SS	G Monel
D 316SS	H Hastelloy-C
F 316L SS	Z Other

4. Gauge connection size

0 ¼"
1 ⅜"
2 ½"
3 ⅝"
Z Other

5. Gauge connection type

A PF (F)
B PT (F)
C NPT (F)
Z Other

6. Process connection size

A ⅝" (10.5 mm)	E ¾"
B ¾"	Q Flange
C ⅞"	Z Other
D 1"	

7. Process connection type

C NPT (F)	N S.W (M)
G PF (M)	P Pipe welding
H PT (M)	Q Flange
J NPT (M)	Z Other
M S.W (F)	

8. Flange size

A N/A	G 1¼" (32A)
D ½" (15A)	H 1½" (40A)
E ¾" (20A)	J 2" (50A)
F 1" (25A)	Z Other

9. Flange rating

KA N/A	KL JIS 10K RF
AC B16.5 Class 150 RF	KN JIS 10K FF
AE B16.5 Class 150 FF	KM JIS 10K RFSF
AD B16.5 Class 150 RFSF	KP JIS 20K RF
AF B16.5 Class 300 RF	KR JIS 20K FF
AH B16.5 Class 300 FF	KQ JIS 20K RFSF
AG B16.5 Class 300 RFSF	KC JIS 30K RF
AJ B16.5 Class 600 RF	KU JIS 30K FF
AL B16.5 Class 600 FF	KJ JIS 30K RFSF
AK B16.5 Class 600 RFSF	ZZ Other

10. Pipe length

000	⅝" SCH 40 (17.3Ø X 2.3t), 100 mm (Only available with flange type)
010	⅝" SCH 80 (17.3Ø X 3.2t), 100 mm (Only available with flange type)
020	½" SCH 40 (21.7Ø X 2.8t), 100 mm (Only available with flange type)
030	½" SCH 80 (21.7Ø X 3.7t), 100 mm (Only available with flange type)
800	None

1	2	3	4	5	6	7	8	9	10
A020	N	C	0	A	A	C	A	KA	000

Sample ordering code

WISE®

A020 : Type of mounting

Code N

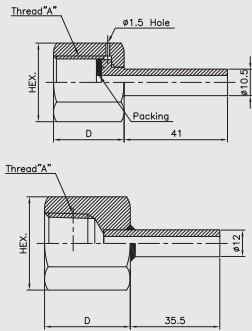

Code P

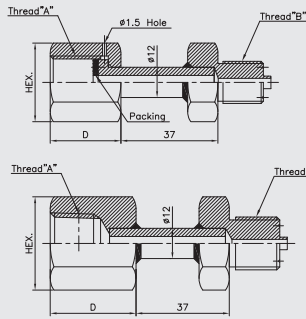

Code Q

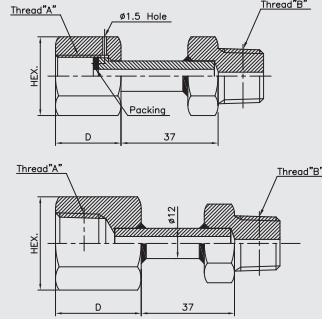

Code R

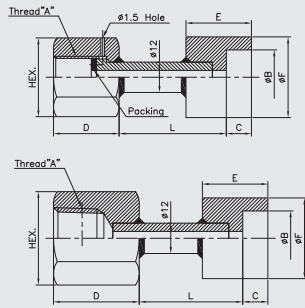

Code S

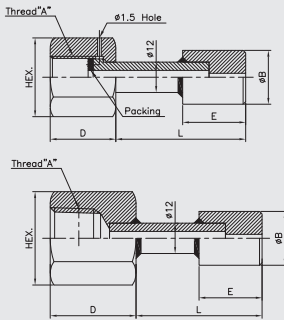

Code T

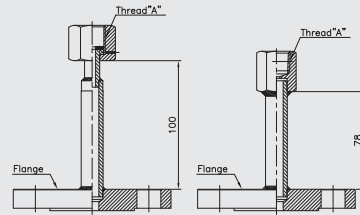

Dimensions (mm)																				
Code	A		B	D	Code	A		B	C	D	E	F	L							
N	PF	3/8"	X	26	R	PF	3/8"	3/8"	10	26	26	26	41							
		1/2"		1/2"				32												
	(N)PT	1/2"		34																
P	PF	3/8"	PF 3/8"	26			3/8"	1/2"				3/8"		13	28	30(32)	29	40		
			PF 1/2"									1/2"					26	32		
			PF 3/4"									3/4"					29	40		
	(N)PT	3/8"	PF 3/8"	30(32)		3/8"	10	26	26	34	26	40								
			PF 1/2"			1/2"			26			32								
			PF 3/4"			3/4"			29			40								
Q	PF	3/8"	(N)PT 3/8"	26		S	PF	1/2"	3/8"	X	28	25	X	50						
			(N)PT 1/2"						1/2"			26		51						
			(N)PT 3/4"						3/4"			25		50						
		1/2"	(N)PT 3/8"		28		34		1/2"			26		51						
			(N)PT 1/2"									1/2"		26						
			(N)PT 3/4"									3/4"		26						
	(N)PT	3/8"	(N)PT 3/8"	30(32)	T	PF	3/8"	1/2"	ANSI	150, 300, 600lb	15, 20, 25, 32, 40, 50A	1 1/4, 1 1/2, 2B	FF RF							
			(N)PT 1/2"											34						
			(N)PT 3/4"																	
		1/2"	(N)PT 3/8"			34									PF	3/8"	ANSI	150, 300, 600lb	15, 20, 25, 32, 40, 50A	1 1/4, 1 1/2, 2B
			(N)PT 1/2"																	
			(N)PT 3/4"																	
Code						A		Flange rating												