

CC-D

Digital Compression Load Cell



P/F



Hopper



Tank



Truck

● DIMENSION

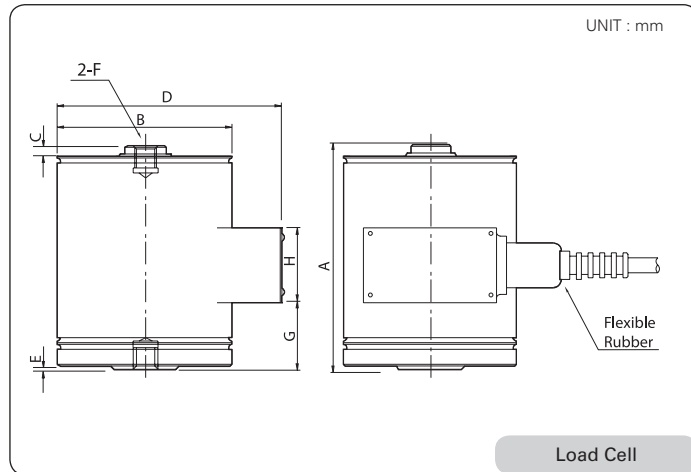

Load Cell

Capa.	A	ØB	C	D	E	F	G	H	Cable(m)
20kgf	115	89	6	115	1.5	M12 x 1.25	38.5	38	5
50kgf									
100kgf									
200kgf	115	89	5	115	1.5	M12 x 1.25	35	38	
300kgf									
500kgf									
1tf	148	89	9	115	1	M24 x 2.0	55	38	
2tf									
3tf									
5tf	215	127	12	152	1.6	M39 x 2.0	75.6	38	
10tf									
20tf									
	290	165	15	193	1.6	M50 x 2.0	107.6	38	10

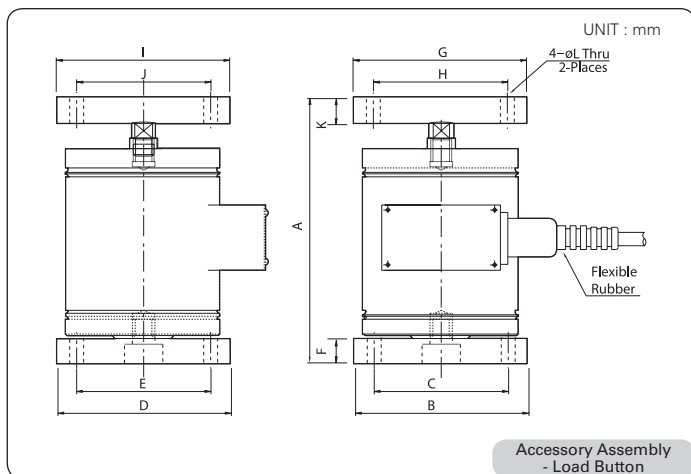

Accessory Assembly
- Load Button

Capa.	A	B	C	D	E	F	G	H	I	J	K	ØL
20kgf	153.7	100	77	100	77	15	100	77	100	77	15	8
50kgf												
100kgf												
200kgf	210.3	130	105	130	105	23	130	105	130	105	23	12
300kgf												
500kgf												
1tf	303	160	125	160	125	30	165	125	165	125	30	14
2tf												
3tf												
5tf	375.5	200	150	200	150	30	200	150	200	150	30	14
10tf												
20tf												

