

6" FND

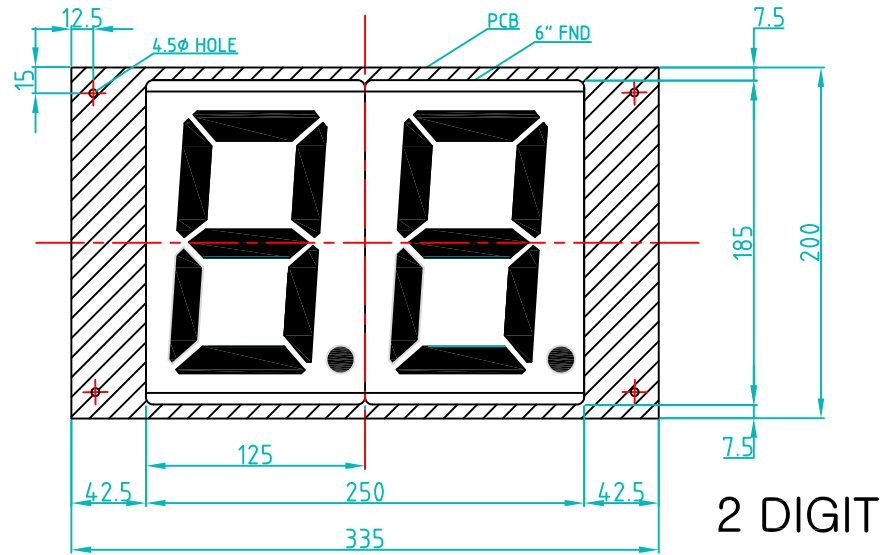
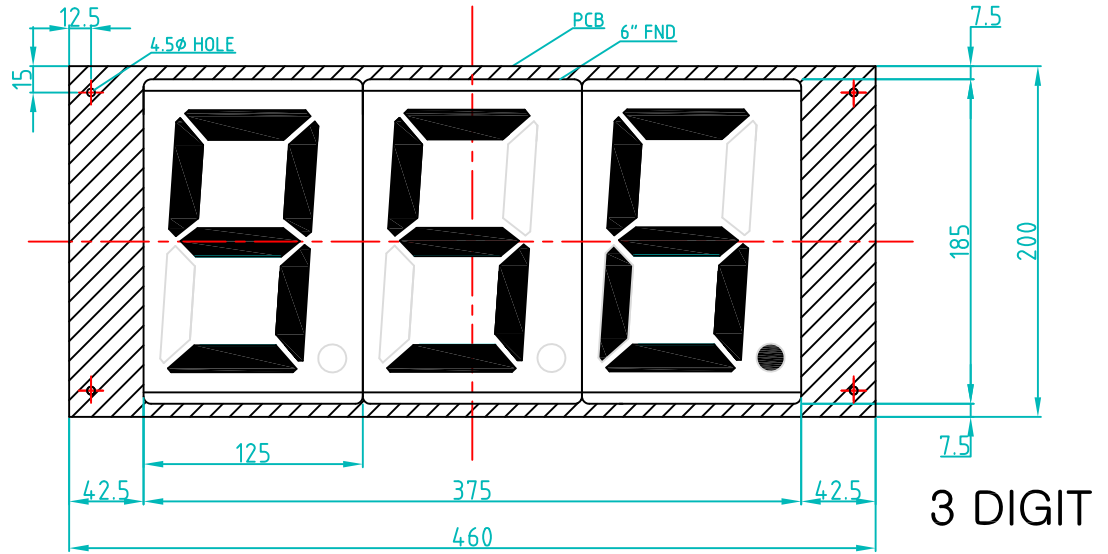
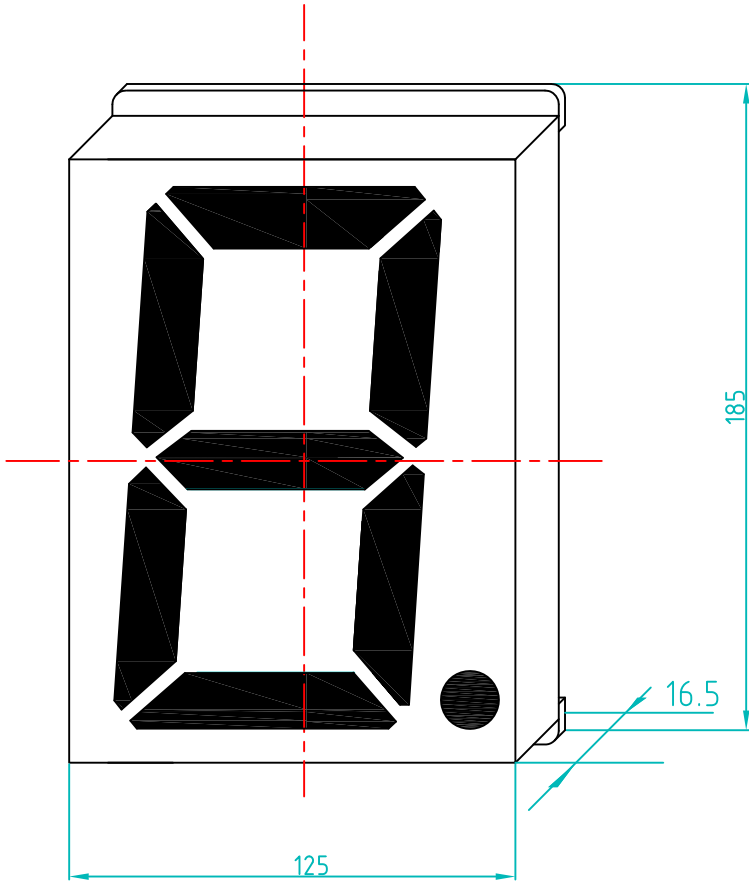

3 DIGIT

2 DIGIT

THIS DRAWING AND SPECIFICATIONS HEREIN ARE THE PROPERTY OF THE NEWINS AND MUST NOT BE LOANED OR OTHERWISE TRANSFERRED TO ANY THIRD PARTY OR REPRODUCED COPIED, OR USED IN CONNECTION WITH THE MANUFACTURE, PURCHASE, OR SALE OF ITEMS WITHOUT WRITTEN CONSENT OF NEWINS

DIMENSIONS ARE ON MILLI METER GENERAL MACHINING TOLERANCES  
 ABOVE 1 UNDER 4 ±0.1  
 GREATER THEN 4 UNDER 16 ±0.2  
 GREATER THEN 16 UNDER 63 ±0.3  
 GREATER THEN 63 UNDER 250 ±0.5  
 GREATER THEN 250 UNDER 1000 ±0.8  
 ANGLE DIMENSIONS ±0.5

DRAWING TITLE :  
 IC-9560PP FND & DIGIT

PROJECTION	THIRD ANGLE PROJECTION		
FINISH	Q'TY		
SCALE	N/S	UNIT	mm
DWG.NO.			

**NEWINS** co.,ltd.

	SIGNATURE	DATE
DRAWN	YOO J.H.	17. 8. 7
DESIGNED		
CHECKED		
APPROVED		

NO.	DESCRIPTION	DATE	REVISIONS BY	APPROVED BY
REVISION				

3 DIGIT 전면부 아크릴창

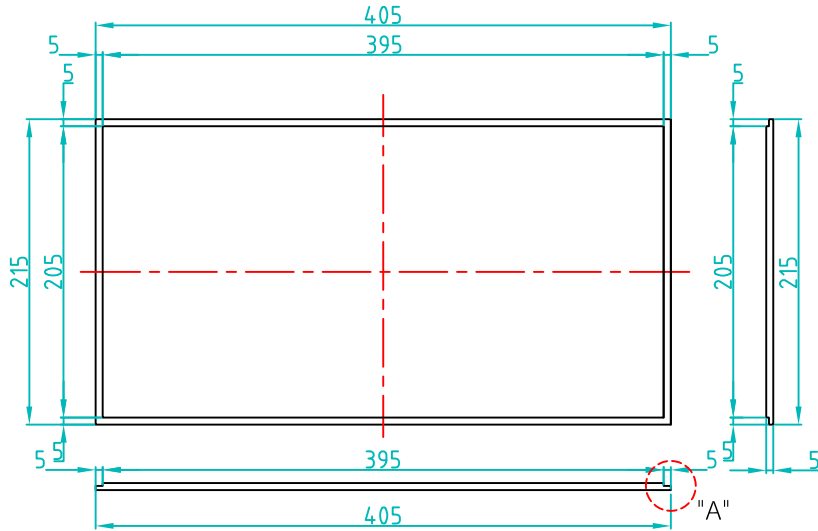

3 DIGIT PANNEL CUTTING SIZE

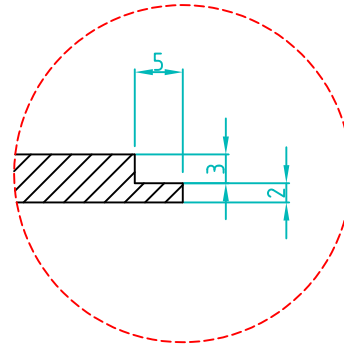
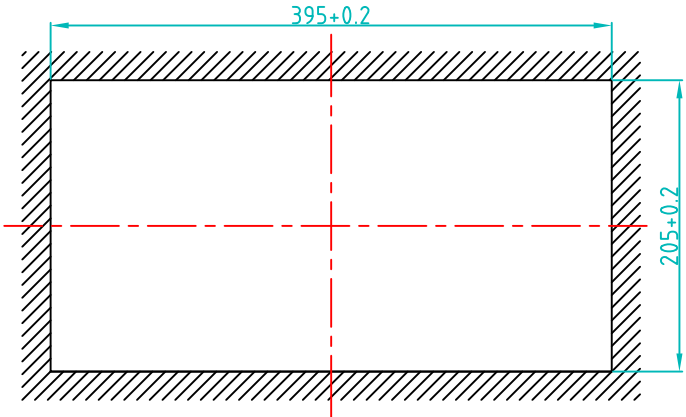

DETAIL "A"

2 DIGIT 전면부 아크릴창

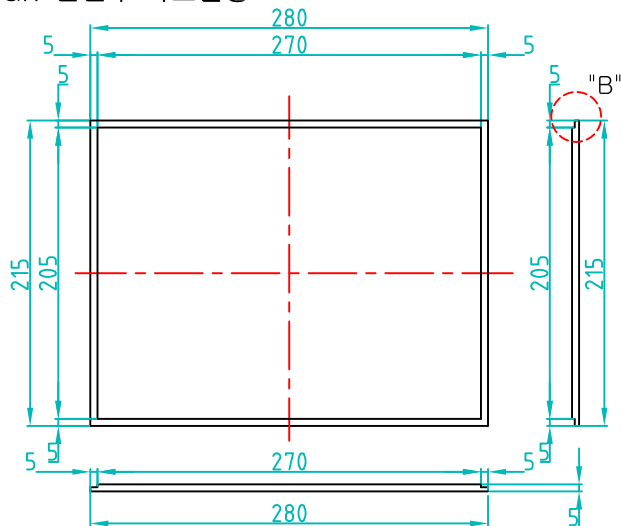

2 DIGIT PANNEL CUTTING SIZE

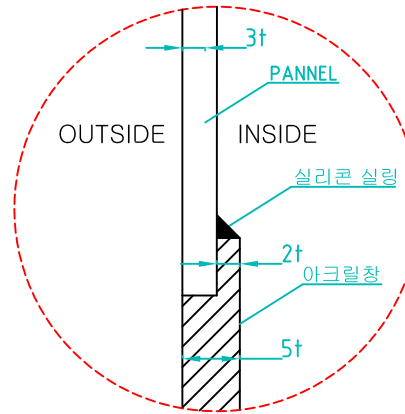
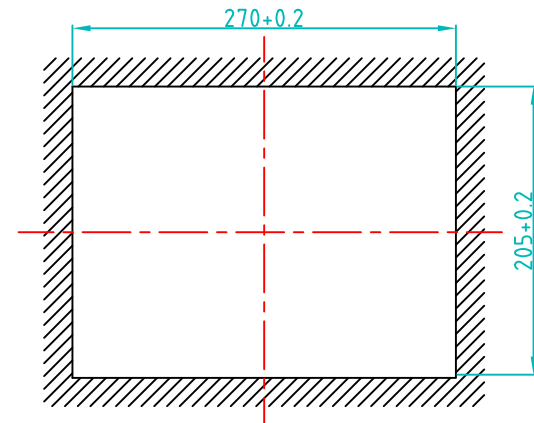

DETAIL "B"

- NOTE 1. 5.0t NCT 가공  
2. 투명 아크릴에 적색 코팅

NO.	DESCRIPTION	DATE	REVISIONS BY	APPROVED BY
REVISION				

THIS DRAWING AND SPECIFICATIONS HEREIN ARE THE PROPERTY OF THE NEWINS AND MUST NOT BE LOANED OR OTHERWISE TRANSFERRED TO ANY THIRD PARTY OR REPRODUCED COPIED, OR USED IN CONNECTION WITH THE MANUFACTURE, PURCHASE, OR SALE OF ITEMS WITHOUT WRITTEN CONSENT OF NEWINS

DIMENSIONS ARE ON MILLI METER GENERAL MACHINING TOLERANCES  
 ABOVE 1 UNDER 4 ±0.1  
 GREATER THEN 4 UNDER 16 ±0.2  
 GREATER THEN 16 UNDER 63 ±0.3  
 GREATER THEN 63 UNDER 250 ±0.5  
 GREATER THEN 250 UNDER 1000 ±0.8  
 ANGLE DIMENSIONS ±0.5

DRAWING TITLE :  
IC-9560PP 아크릴창

PROJECTION	THIRD ANGLE PROJECTION		
FINISH	Q'TY	UNIT	mm
SCALE	N/S	UNIT	mm
DWG.NO.			

**NEWINS** co.,ltd.

	SIGNATURE	DATE
DRAWN	YOO J.H.	17. 8. 7
DESIGNED		
CHECKED		
APPROVED		

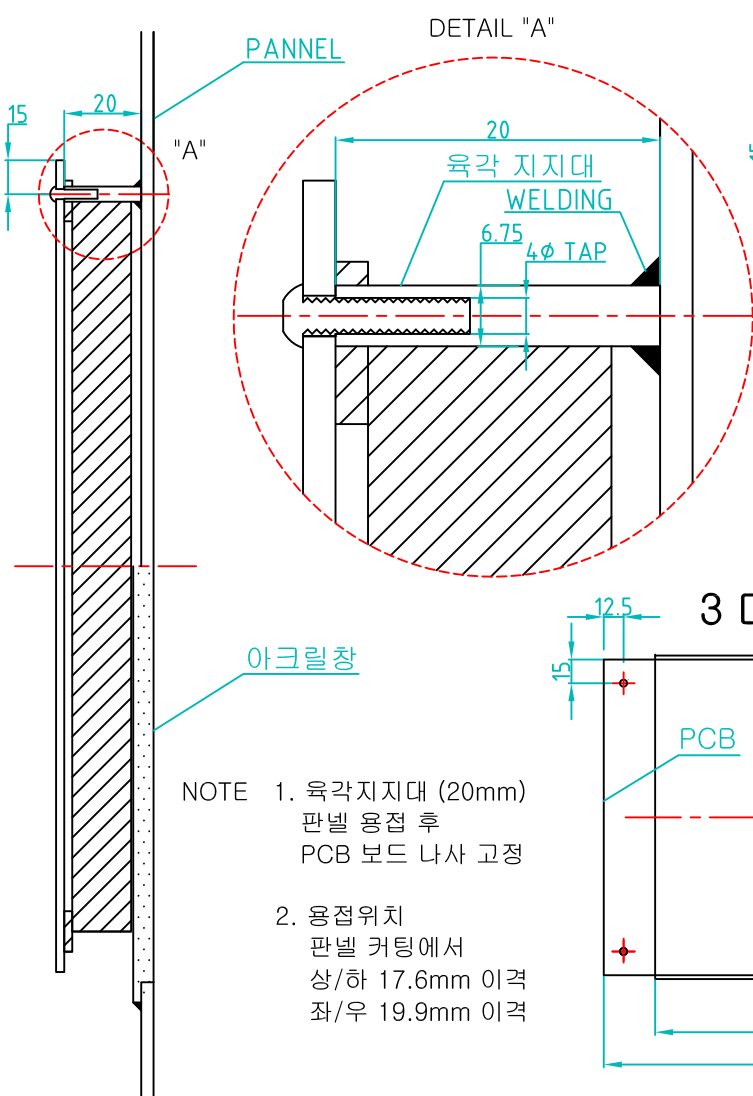
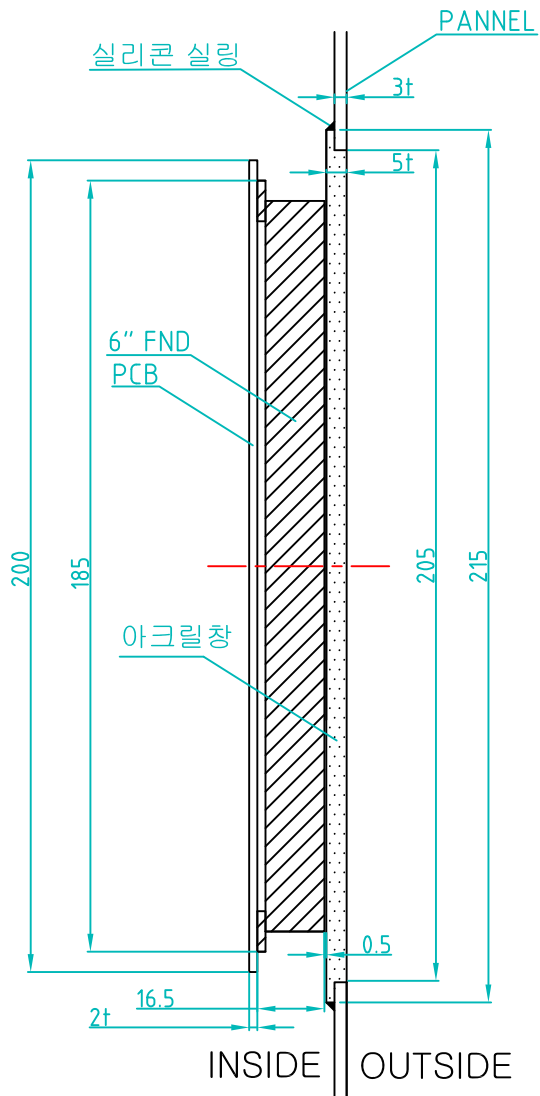

NOTE 1. 육각지지대 (20mm)  
 판넬 용접 후  
 PCB 보드 나사 고정

2. 용접위치  
 판넬 커팅에서  
 상/하 17.6mm 이격  
 좌/우 19.9mm 이격

2 DIGIT

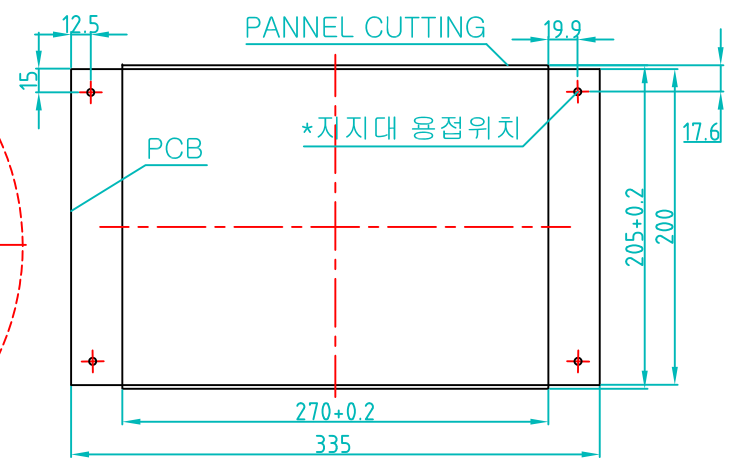

3 DIGIT

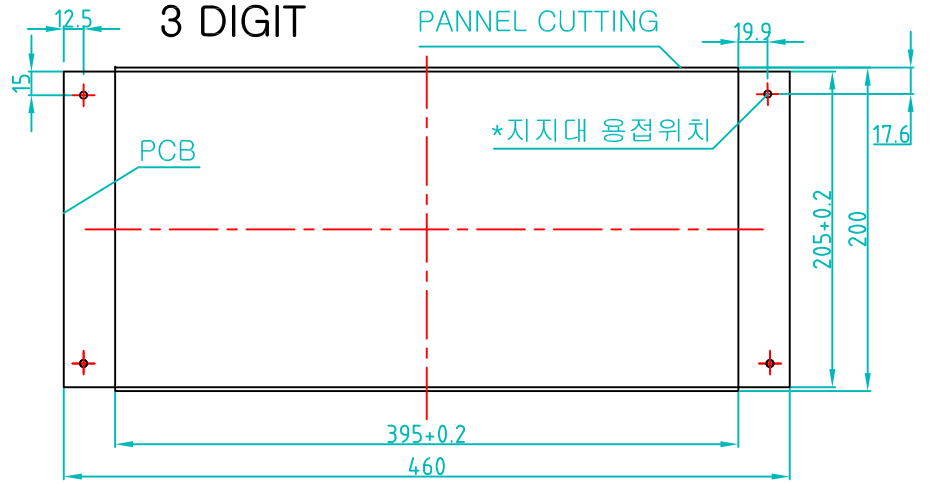

THIS DRAWING AND SPECIFICATIONS HEREIN ARE THE PROPERTY OF THE NEWINS AND MUST NOT BE LOANED OR OTHERWISE TRANSFERRED TO ANY THIRD PARTY OR REPRODUCED COPIED, OR USED IN CONNECTION WITH THE MANUFACTURE, PURCHASE, OR SALE OF ITEMS WITHOUT WRITTEN CONSENT OF NEWINS

DRAWING TITLE :  
 IC-9560PP 취부

**NEWINS** co.,ltd.

DIMENSIONS ARE ON MILLI METER GENERAL MACHINING TOLERANCES

ABOVE 1	UNDER 4	±0.1
GREATER THEN 4	UNDER 16	±0.2
GREATER THEN 16	UNDER 63	±0.3
GREATER THEN 63	UNDER 250	±0.5
GREATER THEN 250	UNDER 1000	±0.8
ANGLE DIMENSIONS		±0.5

PROJECTION	THIRD ANGLE PROJECTION		
FINISH	Q'TY		
SCALE	N/S	UNIT	mm
DWG.NO.			

	SIGNATURE	DATE
DRAWN	YOO J.H.	17. 8. 7
DESIGNED		
CHECKED		
APPROVED		

NO.	DESCRIPTION	DATE	REVISIONS BY	APPROVED BY
REVISION				

POWER  
AC 85 ~ 265V  
45~65Hz

R S FG

| | |

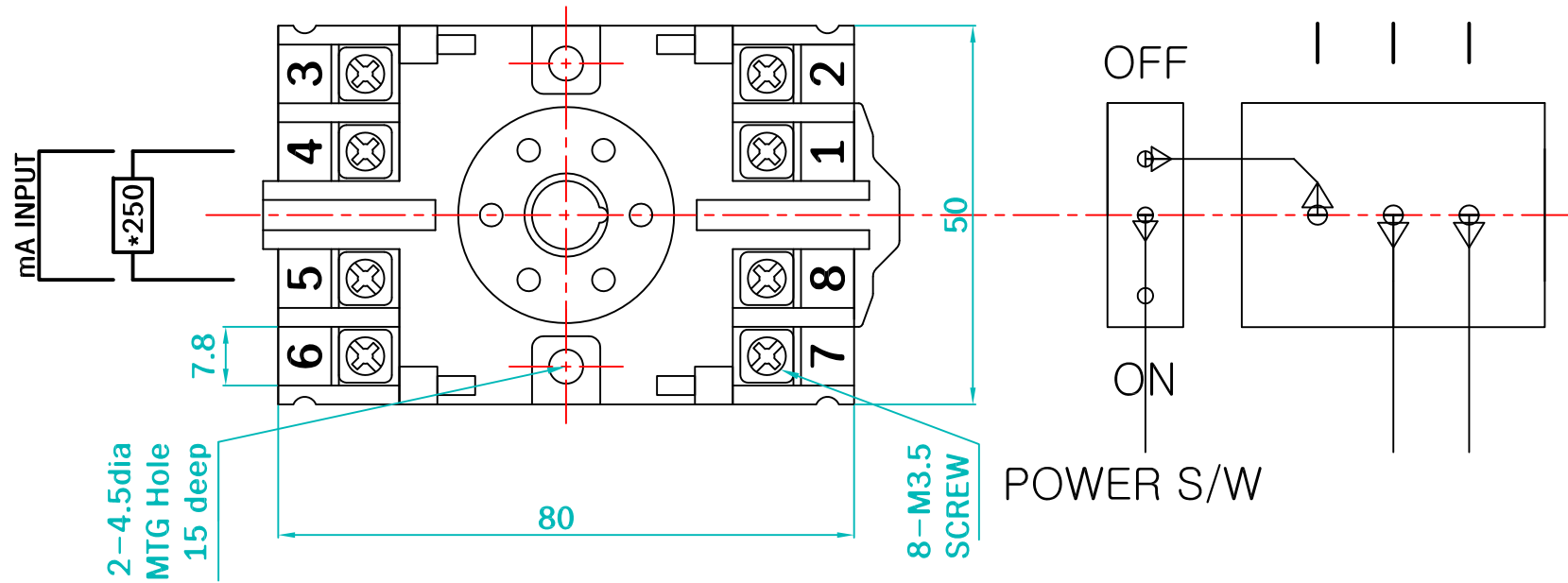

THIS DRAWING AND SPECIFICATIONS HEREIN ARE THE PROPERTY OF THE NEWINS AND MUST NOT BE LOANED OR OTHERWISE TRANSFERRED TO ANY THIRD PARTY OR REPRODUCED COPIED, OR USED IN CONNECTION WITH THE MANUFACTURE, PURCHASE, OR SALE OF ITEMS WITHOUT WRITTEN CONSENT OF NEWINS

DRAWING TITLE :

IC-9560PP 결선도

**NEWINS** co.,ltd.

DIMENSIONS ARE ON MILLI METER GENERAL MACHINING TOLERANCES  
 ABOVE 1 UNDER 4 ±0.1  
 GREATER THEN 4 UNDER 16 ±0.2  
 GREATER THEN 16 UNDER 63 ±0.3  
 GREATER THEN 63 UNDER 250 ±0.5  
 GREATER THEN 250 UNDER 1000 ±0.8  
 ANGLE DIMENSIONS ±0.5

PROJECTION	THIRD ANGLE PROJECTION		
FINISH		Q'TY	
SCALE	N/S	UNIT	mm
DWG.NO.			

	SIGNATURE	DATE
DRAWN	YOO J.H.	17. 8. 7
DESIGNED		
CHECKED		
APPROVED		

NO.	DESCRIPTION	DATE	REVISIONS BY	APPROVED BY
REVISION				







NO.	SPECIFICATION	MAT'L	UNIT	Q'TY	TOTAL WEIGHT (kg)		REMARKS
					UNIT	TOTAL	

EXAMPLE

DIGITAL DISPLAY BOARD \_ DATA LIST

No.	NAME	RANGE	RANGE	RANGE	REMARK
		#1 MILL	#2 MILL	#3 MILL	
1	급 탄 량	0-99 T/H	0-99 T/H	0-99 T/H	
2	MILL 차압	0-99 mBar	0-99 mBar	0-99 mBar	
3	취 입 량	0-99 T/H	0-99 T/H	0-99 T/H	
4	MILL 출구온도	0-999 ?	0-999 ?	0-999 ?	
5	산소 농도	0-99.9 %	0-99.9 %	0-99.9 %	
6	CO 농도	0-99.9 %	0-99.9 %	0-99.9 %	
7	S/B 재고량	0-999 T		0-999 T	

\* NOTE

1. This data can be adjusted regardless of the number at site.
2. TOTAL DATA No. : UNLIMITED

ENG RESP :				CREA NO :			
						Dimension	Projection
						mm	
Approved	Date	Name/Comp.	Project	Facility			
Reviewed			Title				
Checked							
Drawn			Scale		NONE	Format: A3	Major Desg. No. POSCO E&C Desg. No. CSP Desg. No.
Issue for							

THIS DRAWING IS THE PROPERTY OF POSCO E&C COMPANY LIMITED AND MUST NOT BE PASSED ON TO ANY PERSON OR BODY NOT AUTHORISED BY US TO RECEIVE IT NOR BE COPIED OR OTHERWISE MADE USE EITHER IN PART BY SUCH PERSON OR BODY WITHOUT OUR PRIOR PERMISSION IN WRITING.

No.	Date	Description	Drawn	Checked	Reviewed	Approved