

Air regulator service pressure gauge fully stainless steel wetted parts

Model : P113 series

Spec. sheet no. PD01-04

Service intended

P113 series are specifically designed for CDA (Clean dry air) application regulators used in electronic, medical, biotechnology and pharmaceutical industry.

ERC

Nominal diameter

50 mm (2")

Accuracy

±1.6 % of full scale

Scale range (MPa, bar)

0 ~ 40 MPa

Working pressure

Steady : 75 % of full scale

Over range protection : 130 % of full scale

Working temperature

Ambient : -40 ~ 65 °C

Fluid : Max. 200 °C

Temperature effect

Accuracy at temperature above and below the reference temperature (20 °C) will be effected by approximately ±0.4 % per 10 °C of full scale

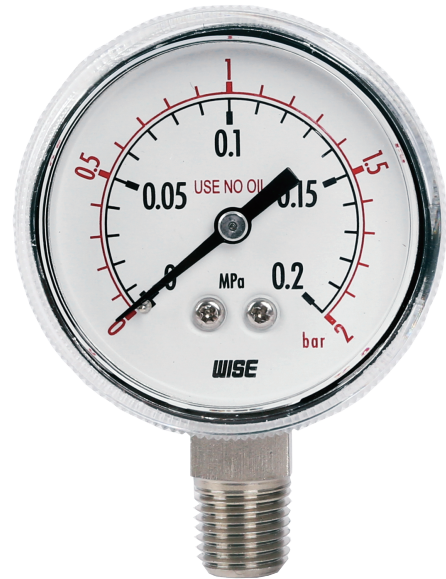

Standard features

Pressure connection

316SS

Ring and window

Twist-lock polycarbonate

Element

316SS

<6 MPa : C-type bourdon tube

≥6 MPa : Helical type bourdon tube

Pointer

Black painted aluminium alloy

Case

304SS

Process connection

¼" NPT

Movement

Brass

Dial

White aluminium with pointer stop pin

With black/red lettering, dual pressure scale (bar/psi and MPa/bar)

WISE[®]

| P113_01

1. Base model

P113 Pressure gauge for regulator use

2. Nominal diameter (mm)

1 50

3. Type of mounting

A Bottom connection, direct

4. Accuracy

4 ±1.6 % of full scale

5. Process connection

C ¼"

6. Connection type

D NPT

7. Unit

Q bar/psi

Y MPa/bar

8. Range

XXX Refer to pressure unit and range table

9. Dial color

6 3 colors

10. Option

0 None

1 Accessories

1	2	3	4	5	6	7	8	9	10
P113	1	A	4	C	D	Q	XXX	6	0

Sample
ordering code

P113 : Type of mounting

Code A

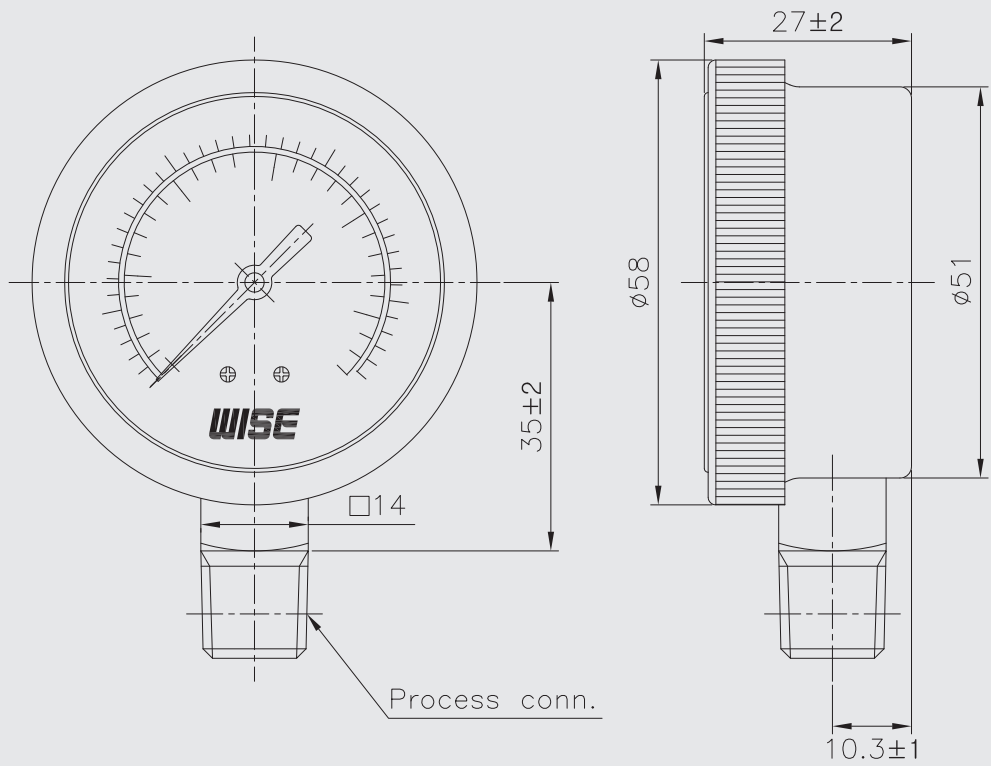

Pressure unit and range table

Range and code	Unit and code	
	Q : bar	Y : MPa
042	0 ~ 2	0 ~ 0.2
044	0 ~ 4	0 ~ 0.4
046	0 ~ 7	0 ~ 0.7
142	0 ~ 14	0 ~ 1.4
051	0 ~ 20	0 ~ 2
151	0 ~ 40	0 ~ 4
057	0 ~ 70	0 ~ 7
170	0 ~ 140	0 ~ 14
172	0 ~ 210	0 ~ 21
174	0 ~ 270	0 ~ 27
065	0 ~ 400	0 ~ 40
028	-1 ~ 2	-0.1 ~ 0.2
012	-1 ~ 7	-0.1 ~ 0.7
016	-1 ~ 11	-0.1 ~ 1.1
033	-1 ~ 14	-0.1 ~ 1.4
034	-1 ~ 20	-0.1 ~ 2