

Draft gauge

Model : P410, P420 series

Spec. sheet no. PD04-01

Service intended

P410 and P420 series are designed to measure low, vacuum or compound pressure.
These series are available in panel mounting.

EAC

Nominal diameter

192 (W) x 96 mm (H) (P type)
96 (W) x 192 mm (H) (R type)

Accuracy

±2.0 or ±3.0 % of full scale

Scale range (MPa, kPa, bar)

Vacuum : -1 ~ 0 to -0.5 ~ 0 kPa
Compound : -0.2 ~ 0.2 to -5 ~ 5 kPa
Pressure : 0 ~ 0.5 to 0 ~ 10 kPa

Working pressure

Steady : 75 % of full scale
Over range protection : 130% of full scale

Working temperature

Ambient : -20 ~ 65 °C
Fluid : Max. 100 °C

Temperature effect

Accuracy at temperature above and below the reference temperature (20 °C) will be effected by approximately ±1.0 % per 10 °C of full scale



Standard features

Pressure connection

Stainless steel (316SS)

Dial

White aluminium with black graduations

Element

Stainless steel (316L SS)

Case

Black finished steel : P410
Black finished stainless steel (304SS) : P420

Pointer

Black painted PBs2 alloy

Window

Safety glass

Movement

Brass

Process connection

3/8", 1/2" PF, NPT and PF

WISE[®]

1. Base model

P410 Square type low pressure gauge,
black finished steel case

P420 Square type low pressure gauge,
stainless steel case

2. Nominal diameter (mm)

9 192 (W) x 96 (H) and 96 (W) x 192 (H)

3. Type of mounting

P Horizontal mounting

R Vertical mounting

4. Accuracy

5 ±2.0 % of full scale

6 ±3.0 % of full scale, only compound and vacuum

5. Process connection

D $\frac{3}{8}$ "

E $\frac{1}{2}$ "

6. Connection type

B PF

C PT

D NPT

Z Other

7. Unit

J kPa

S mbar

8. Range

XXX Refer to pressure unit and range table

9. Pressure connection material and dial color

3 316SS and 2 colors

7 316SS and 3 colors

10. Option

0 None

1 Accessories

1	2	3	4	5	6	7	8	9	10
P410	9	P	5	E	C	J	XXX	3	0

Sample
ordering code

P410, P420 : Type of mounting

Code R

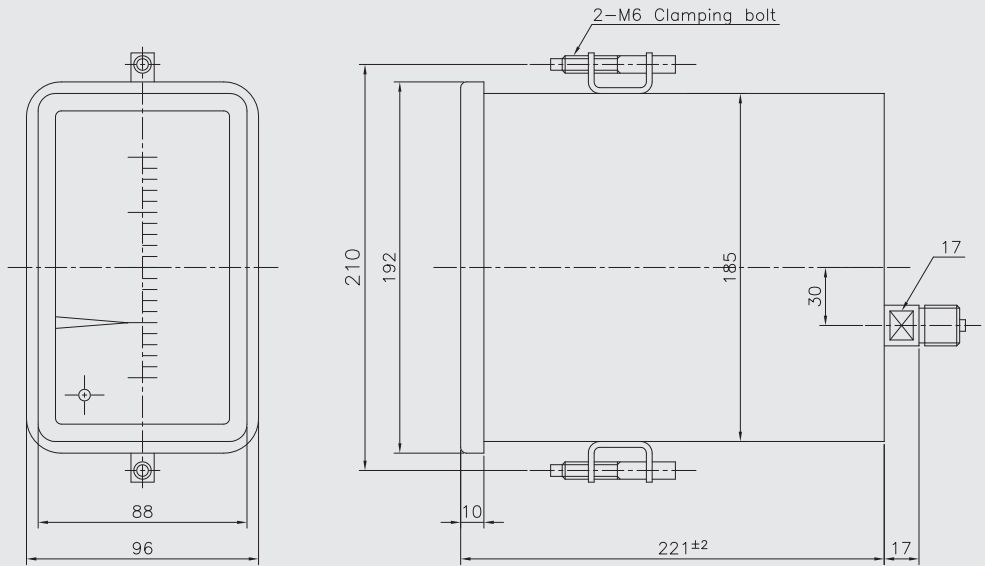

Code P

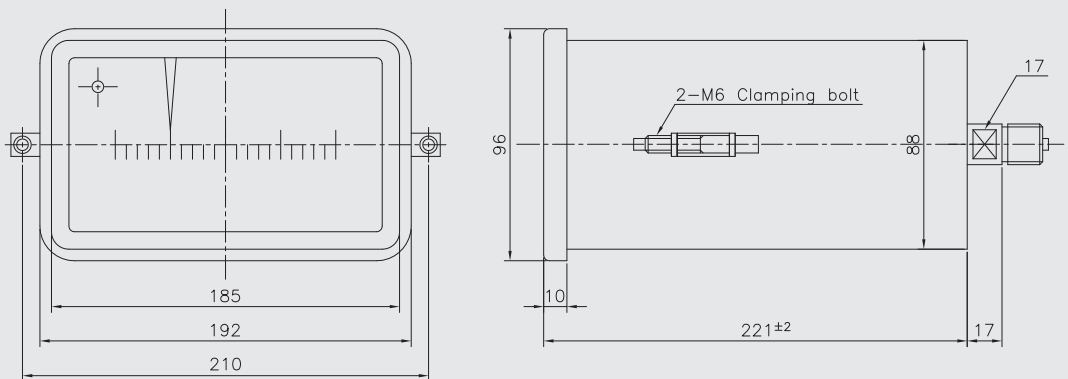

Pressure unit and range table

Range and code	Unit and code		Model number
	S : mbar	J : kPa	P410 and P420
403	-100 ~ 0	-10 ~ 0	O
405	-50 ~ 0	-5 ~ 0	O
407	-30 ~ 0	-3 ~ 0	O
408	-20 ~ 0	-2 ~ 0	O
409	-10 ~ 0	-1 ~ 0	O
410	-5 ~ 0	-0.5 ~ 0	O
413	-50 ~ 50	-5 ~ 5	O
417	-30 ~ 30	-3 ~ 3	O
419	-20 ~ 20	-2 ~ 2	O
421	-10 ~ 10	-1 ~ 1	O
422	-5 ~ 5	-0.5 ~ 0.5	O
423	-3 ~ 3	-0.3 ~ 0.3	O
424	-2 ~ 2	-0.2 ~ 0.2	O
456	0 ~ 5	0 ~ 0.5	O
457	0 ~ 10	0 ~ 1	O
460	0 ~ 20	0 ~ 2	O
462	0 ~ 30	0 ~ 3	O
465	0 ~ 50	0 ~ 5	O
469	0 ~ 100	0 ~ 10	O

O : Available