

Head mounting type multi temperature transmitter

Model : R911 (with T900)

Spec. sheet no. RD09-01

Service intended

T900 series temperature transmitters are designed to fit into a standard molded terminal heads used on RTD and thermocouple assemblies to provide a 4-20 mA transmission signals. It is a cost effective solution for all temperature measuring process. It is accurate, durable and reliable. Numerous configurations for measurement in many deferent mediums are offered. Generally the transmitter produces a linear 4-20 mA output carried on a two-wire system. The transmitter is supplied factory calibrated, but also has zero and span potentiometers for a field adjustment.

Advantages

- Two wire 4-20 mA current output signals
- Universal input signals
 - RTD temperature sensor
 - T/C elements
 - mV, V, mA, DC signals
- Programmable function setting
 - Input signal type
 - Measuring range
 - Burnout Low/High setting
 - mA output offset
- Excellent accuracy and a long term stability
- Low cost effective



Specification

Electrical specification

Excitation voltage : 18 ~ 30 V DC
(Noise range:20 mVp-p)
Load resistance max : 600 Ω with 24 V
Influence of excitation : 0.01 % FSO/V
Reverse polarity : Protected
Shock resistance : No change in performance after 20Gs
Vibration : 0.1 g max.
Response time (10 ~ 90 %) : ± 500 mSec.
Adjustment range : Free

Performance specification

Accuracy : ± 0.2 % FSO
Non - linearity : Better than 0.10 % FSO
Repeatability : Better than 0.05 % FSO
Long term stability : Better than 0.05% FSO per month
Cutoff frequency : ± 1 kHz
Ambient temperature limits : -10 ~ 70 $^{\circ}$ C
Ambient humidity limits : 10 to 90 % R.H

Input

Temperature sensor type : See table "Sensor type, range and accuracy"

Signal source : See table "Sensor type, range and accuracy"

Output

Current output : 4 ~ 20 mA loop powered
Electrical connection type : 2-wire technique
Full scale output signal : 20 mA ± 0.2 %
Zero measured output : 4 mA ± 0.03 %
Sensor burnout : High (20.5 mA DC) or Low (3.9 mA)

Certificates

KCS Ex d IIC T6

1. Base model**R911** Temperature transmitter**2. Head and tip shape type**

- F** Explosion proof and ungrounded
- G** Explosion proof and spring - loaded
- H** Explosion proof and grounded
- K** Explosion proof and exposed
- P** Explosion proof (Double conduit) and ungrounded
- Q** Explosion proof (Double conduit) and grounded
- R** Explosion proof (Double conduit) and exposed
- S** Explosion proof (Double conduit) and spring - loaded

3. Element

- | | |
|-------------------|-----------------------|
| K K (0.75) | 3 T (0.4) |
| J J (0.75) | 4 E (0.4) |
| T T (0.75) | Q Pt 100 Ω (B) |
| N N (0.75) | 9 Pt 100 Ω (A) |
| E E (0.5) | Z Other |
| 1 K (0.4) | |
| 2 J (0.4) | |

4. Sheath or tube material

- 0** 304SS
- 1** 316SS
- 2** Inconel 600
- 3** 310SS
- 4** 446SS
- 5** 347SS
- 6** 321SS
- 7** 316L SS
- 9** Other

5. Sheath or tube/element outer diameter (mm)

- | Sheath type | Tube type |
|---------------|------------------------|
| D9 3.2 | F0 6.4 and 0.65 |
| E9 4.8 | G0 8.0 and 0.65 |
| F9 6.4 | G1 8.0 and 1.0 |
| G9 8.0 | J1 10.0 and 1.0 |
| | J2 10.0 and 1.6 |
| | K1 12.0 and 1.0 |
| | K2 12.0 and 1.6 |
| | M1 15.0 and 1.0 |
| | M2 15.0 and 1.6 |
| | M3 15.0 and 2.3 |
| | P2 17.3 and 1.6 |
| | P3 17.3 and 2.3 |
| | P4 17.3 and 3.2 |
| | Q3 21.7 and 2.3 |
| | Q4 21.7 and 3.2 |
| | F8 6.4 for RTD |
| | G8 8.0 for RTD |
| | J0 10 for RTD |

6. Conduit connection

- 3** ½" NPT
- 6** ¾" NPT
- 7** None
- 8** M20 x 1.5P
- 9** Other

7. Mounting type

- X** Refer to mounting table (11th character)

8. Connection type

- XX** Refer to Connection table (12th and 13th character)

9. Insert length

- X** Refer to insert length table (14th character)

10. Option

- 0** None
- 1** Accessories
- 4** Epoxy coated ALDC head
- 6** Head material : 316SS
- 7** Accessories and epoxy coated ALDC head
- 9** Accessories and head material : 316SS

1	2	3	4	5	6	7	8	9	10	Sample ordering code
R911	F	K	0	D9	3	X	XX	X	4	

1. Base model

T900 Head mounting type multi input 2-wire transmitter

2. Input

- N** Normal input (Standard)
- O** Order input

3. Input signal

- PT** Pt 100 Ω (RTD)
- JP** JPt 100 Ω (RTD)
- TR** R type (Thermo couple)
- TK** K type (Thermo couple)
- TE** E type (Thermo couple)
- TJ** J type (Thermo couple)
- TT** T type (Thermo couple)
- TB** B type (Thermo couple)
- TS** S type (Thermo couple)
- TN** N type (Thermo couple)
- mV** mV Input (Signals)
- mA** mA Input (Signals)
- DV** Voltage Input (Signals)

4. Measuring range (°C)

- 01** -50 ~ 0
- 02** -50 ~ 50
- 03** -20 ~ 80
- 04** -50 ~ 150
- 05** 0 ~ 100
- 06** 0 ~ 200
- 07** 0 ~ 300
- 08** 0 ~ 400
- 09** 0 ~ 500
- 10** 0 ~ 600
- 11** 0 ~ 700
- 12** 0 ~ 800
- 13** 0 ~ 900
- 14** 0 ~ 1000
- XX** Other calibration ranges available on request

5. Calibration

- C** Celsius scale °C
- F** Celsius scale °F

6. Output signal

- C** DC 4 ~ 20 mA current
- V** DC 1 ~ 5 V Voltage
- N** Non-output
- X** Other signal available on request

7. Transmitter option

- A** Hart temperature transmitter (ABB, TTH300)
- B** Hart temperature transmitter (SIMENS, TH300)
- C** Hart temperature transmitter (YOKOGAWA, YTA70)
- D** Hart temperature transmitter (ROSEMOUNT, 644H)
- E** Other
- N** None

8. Accessories

- N** None
- L** Hand held program loader
- U** USB type program loader

1	2	3	4	5	6	7	8
T900	N	PT	01	C	C	N	N

Sample ordering code

R911 : Type of mounting

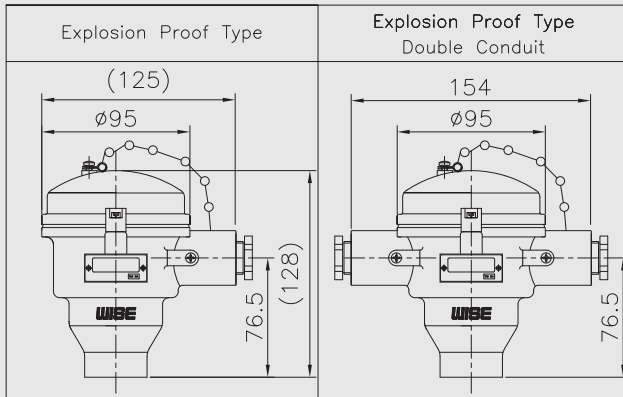

Head

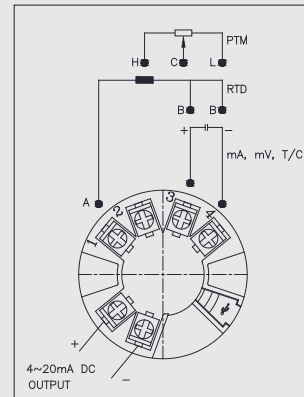

Electrical connection

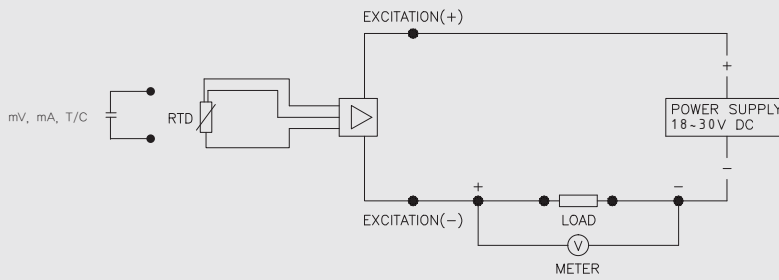

System connection for 2 - wire transmitter

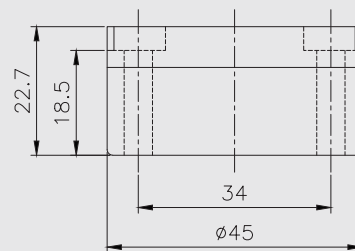
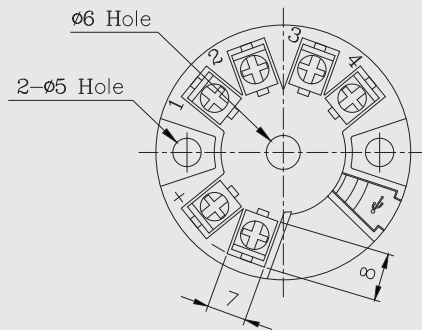

Sensor type, range, accuracy

Resistance temperature detector (RTD)				
Input	Measuring range (°C)	Min.measured span (°C)	Calibration range (°C)	Analog output (mA)Error
Pt100	-200 ~ 850	10	-200 ~ 850	0.2 % of span
JPt100	-200 ~ 650	10	-200 ~ 650	

Thermocouple elements (T/C)				
Input	Measuring range (°C)	Min.measured span (°C)	Calibration range (°C)	Analog output (mA)Error
Type B	100 ~ 1820	300	100 ~ 400	0.2 % of span
		100	400 ~ 1820	
Type E	-200 ~ 1000	50	-200 ~ 1000	
Type J	-200 ~ 1200	50	-200 ~ 1200	
Type K	-200 ~ 1370	50	-200 ~ 1370	
Type N	-200 ~ 1300	50	-200 ~ 1300	
Type R	0 ~ 1760	100	0 ~ 1760	
Type S	0 ~ 1760	100	0 ~ 1760	
Type T	-200 ~ 400	40	-200 ~ 400	

mV, V, mA sensor				
Input	Measuring range	Min.measured span	Calibration range	Analog output (mA)Error
mV	0 ~ 999 mV	2 mV	0 ~ 999 mV	0.2 % of span
V	0 ~ 10 V	1 V	0 ~ 10 V	
mA	0 ~ 30 mA	4 mA	0 ~ 30 mA	
Input resistor : 250 Ω (External)				

Mounting, connection type and insert length table - 11th thru 14th characters

11 th character		12 th character		13 th character		14 th character	
Code	Mounting	Code	Connection size and connector material	Code	Connection type	Code	Insert length (mm)
A	None	A	None	A	None	A	100
	Fixed thread lag length	B	1/8" and 304SS	B	PT	B	200
B	80 mm	C	1/4" and 304SS	C	NPT	C	300
C	100 mm	D	3/8" and 304SS	D	PF	D	400
D	150 mm	E	1/2" and 304SS	E	NPS	E	500
E	200 mm	F	3/4" and 304SS	F	UNF	F	600
F	Other	G	1" and 304SS	G	BSPT	G	700
	Fixed flange lag length	H	1 1/4" and 304SS	H	BSPF	H	800
G	80 mm	J	1 1/2" and 304SS	J	MM	J	900
H	100 mm	K	2" and 304SS	K	B16.5 Class 150 RF	K	1,000
J	150 mm	L	3" and 304SS	L	B16.5 Class 150 FF	L	1,500
K	200 mm	M	7/16" and 304SS	M	B16.5 Class 300 RF	M	2,000
L	Other	N	1/2" and 316SS	N	B16.5 Class 300 FF	N	2,500
M	Movable thread	P	1/4" and 316SS	O	Sanitary	P	3,000
N	Movable flange	Q	3/8" and 316SS	P	B16.5 Class 600 RF	Q	3,500
P	Compression fitting	R	1/2" and 316SS	Q	B16.5 Class 600 FF	R	4,000
	Union and nipple length	S	3/4" and 316SS	R	JIS 5K RF	S	4,500
Q	100 mm length	T	1" and 316SS	S	JIS 5K FF	T	5,000
R	150 mm length	U	1 1/4" and 316SS	T	JIS 10K RF	U	6,000
S	Other	V	1 1/2" and 316SS	U	JIS 10K FF	V	7,000
	Nipple length	W	2" and 316SS	V	JIS 20K RF	W	8,000
T	50 mm	X	3" and 316SS	W	JIS 20K FF	X	9,000
U	100 mm	Y	7/16" and 316SS	X	B16.5 Class 1,500 RTJ	Y	10,000
V	150 mm	Z	Other	Y	B16.5 Class 2,500 RTJ	Z	Other
W	Other			Z	Other		
X	Fixed thread						
Z	Other						

■ Note for 14th character, please choose a code of next higher length if applicable length is not.

Actual length shall be specified.

■ Note for *Y code (Oil sealing type), only available with spring-loaded head type.