

Head mounting type temperature transmitter (RTD only)

Model : R912 (with T990)

Spec. sheet no. RD09-02

Service intended

These transmitters are recommended be used in the situation where the application of RTD signals to carry to a long distance or to guard against the heavy electrical field noise. The transmitters convert RTD inputs to an analog signal for a direct interface with indicators, recorders, controllers, PLC, DCS systems, and these can be used for a wide range of applications in process control, automatic machinery and hydraulic or pneumatic system design.



Advantages

- Two wire 4 - 20 mA current output signal
- RTD input
- Measuring range from -50 ~ 400 °C
- Fixed range
- Excellent accuracy and long term stability
- Low - cost
- Miniature design



Model : T990



Specification

Electrical specification

Excitation voltage : 18 ~ 30 V
Load resistance : Max. 500 Ω at 24 V
Influence of excitation : 0.01 % FSO/V
Burnout : Upscale (Approx. 23 mA DC) or
Down scale (Approx. 4 mA DC)
Reverse polarity : Protected
Shock resistance : No change in performance after
10Gs for 11ms
Vibration : 5g (10 ~ 2,000 Hz)
Response time (10 ~ 90 %) : ± 0.5 seconds
Adjustment range : ± 15 % of full scale / Zero and span

Performance specification

Accuracy : ± 0.2 % of full scale
Non - linearity : Better than 0.10 % of full scale
Repeatability : Better than 0.05 % of full scale
Long term stability : Better than 0.05 % of full scale per month
Ambient temperature limits : -20 ~ 70 °C
Ambient humidity limits : 5 ~ 95 % R.H

Input

Measuring element : Pt 100 Ω at 0 °C

Output

Current output
Electrical connection type : 2-wire technique
Full scale output signal : 20 mA ± 0.2 %
Zero measured output : 4 mA ± 0.03 %
Other output signals available on request

Certificates

KCS Ex d IIC T6

1. Base model**R912** Temperature transmitter (RTD only)**2. Head and tip shape type**

- F** Explosion proof and ungrounded
- G** Explosion proof and spring - loaded
- P** Explosion proof (Double conduit) and ungrounded
- S** Explosion proof (Double conduit) and spring - loaded

3. Element

- Q** Pt 100 Ω (B)
- 9** Pt 100 Ω (A)

4. Sheath or tube material

- 0** 304SS
- 1** 316SS
- 7** 316L SS
- 9** Other

5. Sheath or tube outer diameter (mm)

Sheath type	Tube type
D9 3.2	E8 4.8
E9 4.8	F8 6.4
F9 6.4	G8 8.0
G9 8.0	J0 10.0

6. Conduit connection

- 3** ½" NPT
- 6** ¾" NPT
- 7** None
- 8** M20 x 1.5P
- 9** Other

7. Mounting type

- X** Refer to mounting table (11th character)

8. Connection type

- XX** Refer to Connection table (12th and 13th character)

9. Insert length

- X** Refer to insert length table (14th character)

10. Option

- 0** None
- 1** Accessories
- 4** Epoxy coated ALDC head
- 6** Head material : 316SS
- 7** Accessories and epoxy coated ALDC head
- 9** Accessories and head material : 316SS

1	2	3	4	5	6	7	8	9	10
R912	F	Q	7	F9	3	X	XX	X	4

Sample
ordering code

1. Base model**T990** Temperature transmitter**2. Input type****RJ** Pt 100 Ω **3. Measuring range (°C)****05** 0 ~ 50**10** 0 ~ 100**15** 0 ~ 150**20** 0 ~ 200**25** 0 ~ 250**30** 0 ~ 300**40** 0 ~ 400**50** 0 ~ 500**51** 50 ~ 150**55** 50 ~ 150**12** 100 ~ 200**13** 100 ~ 300**N0** -50 ~ 50**N1** -50 ~ 100**N5** -50 ~ 150**N2** -50 ~ 200**ZZ** Special**4. Burn-out****U** Up scale**D** Down scale

1	2	3	4	Sample ordering code
T990	RJ	05	U	

R912 : Type of mounting

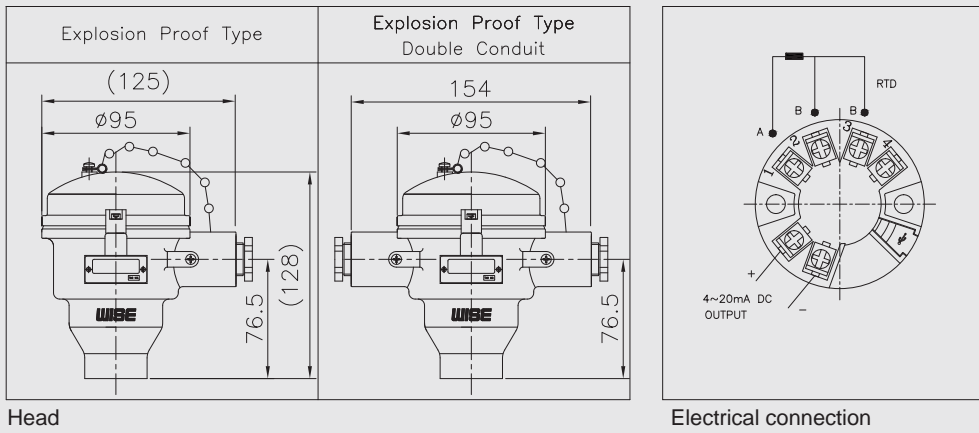

Head

Electrical connection

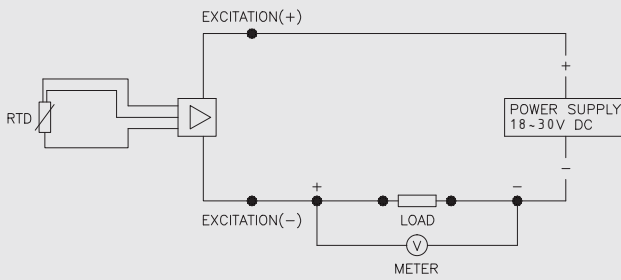

System connection for 2 - wire transmitter

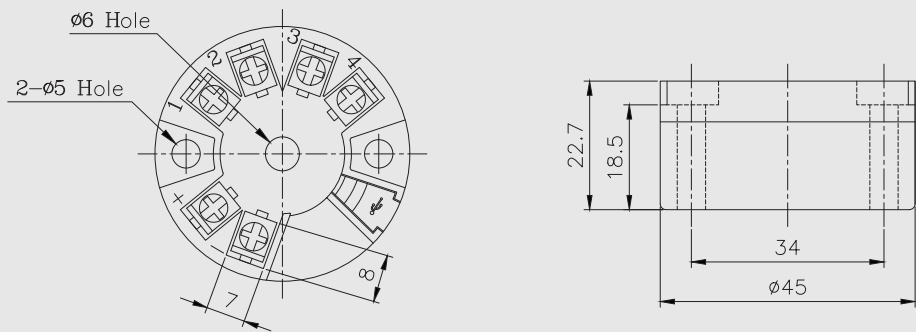

Mounting, connection type and insert length table - 11th thru 14th characters

11 th character		12 th character		13 th character		14 th character	
Code	Mounting	Code	Connection size and connector material	Code	Connection type	Code	Insert length (mm)
A	None	A	None	A	None	A	100
	Fixed thread lag length	B	1/8" and 304SS	B	PT	B	200
B	80 mm	C	1/4" and 304SS	C	NPT	C	300
C	100 mm	D	3/8" and 304SS	D	PF	D	400
D	150 mm	E	1/2" and 304SS	E	NPS	E	500
E	200 mm	F	3/4" and 304SS	F	UNF	F	600
F	Other	G	1" and 304SS	G	BSPT	G	700
	Fixed flange lag length	H	1 1/4" and 304SS	H	BSPF	H	800
G	80 mm	J	1 1/2" and 304SS	J	MM	J	900
H	100 mm	K	2" and 304SS	K	B16.5 Class 150 RF	K	1,000
J	150 mm	L	3" and 304SS	L	B16.5 Class 150 FF	L	1,500
K	200 mm	M	7/16" and 304SS	M	B16.5 Class 300 RF	M	2,000
L	Other	N	1/2" and 316SS	N	B16.5 Class 300 FF	N	2,500
M	Movable thread	P	1/4" and 316SS	O	Sanitary	P	3,000
N	Movable flange	Q	3/8" and 316SS	P	B16.5 Class 600 RF	Q	3,500
P	Compression fitting	R	1/2" and 316SS	Q	B16.5 Class 600 FF	R	4,000
	Union and nipple length	S	3/4" and 316SS	R	JIS 5K RF	S	4,500
Q	100 mm length	T	1" and 316SS	S	JIS 5K FF	T	5,000
R	150 mm length	U	1 1/4" and 316SS	T	JIS 10K RF	U	6,000
S	Other	V	1 1/2" and 316SS	U	JIS 10K FF	V	7,000
	Nipple length	W	2" and 316SS	V	JIS 20K RF	W	8,000
T	50 mm	X	3" and 316SS	W	JIS 20K FF	X	9,000
U	100 mm	Y	7/16" and 316SS	X	B16.5 Class 1,500 RTJ	Y	10,000
V	150 mm	Z	Other	Y	B16.5 Class 2,500 RTJ	Z	Other
W	Other			Z	Other		
X	Fixed thread						
Z	Other						

- Note for 14th character, please choose a code of next higher length if applicable length is not. Actual length shall be specified.
- Note for *Y code (Oil sealing type), only available with spring-loaded head type.

A large, empty rectangular box with a thin black border, intended for writing a memo.