

Flapper type sight glass

Model : S200 series

Spec. sheet no. SD02-01

Description

Sight glass with flapper can check the state of fluid flow by opening and closing the flapper.

Model : S200

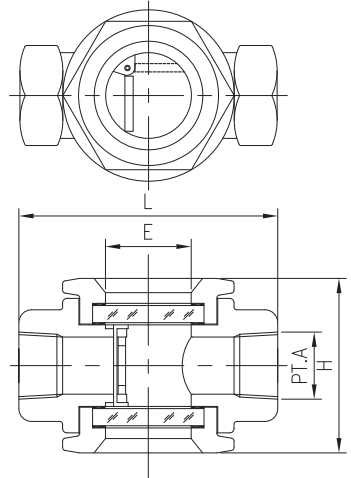
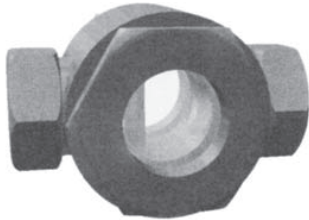

Connections

Screwed end

Max. pressure

2.9 MPa

Max. temperature

300 °C

Glass

Tempered

Body material

A216 WCB

A351 CF8

A351 CF8M

A106 Gr.B

Dimension

Size A(")	L	H (Approx.)	E
8 (½)	120	105	50
10 (¾)	120	105	50
15 (½)	120	105	50
20 (¾)	120	105	50
25 (1)	140	115	50
32 (1¼)	160	130	65
40 (1½)	160	130	65
50 (2)	180	140	80

Model : S210

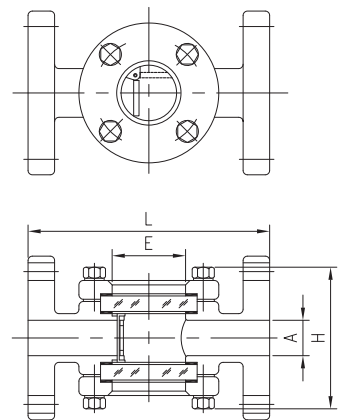

Connections

Flanged end

Max. pressure

2.9 MPa

Max. temperature

300 °C

Glass

Tempered

Body material

A216 WCB

A351 CF8

A351 CF8M

A106 Gr.B

Dimension

Size A(")	L	H (Approx.)	E
15 (½)	160	130	40
20 (¾)	160	130	40
25 (1)	170	135	50
32 (1¼)	200	160	65
40 (1½)	200	160	65
50 (2)	220	175	75
65 (2½)	270	200	105
80 (3)	270	200	105
100 (4)	320	240	130
125 (5)	380	280	170
150 (6)	420	310	200
200 (8)	500	370	260

1. Base model

- S200** Flapper type (Screwed)
S210 Flapper type (Flanged)

2. Line size

JIS	mm	ANSI	inch	DIN	mm
J015	15A	A001	½B	D015	15A
J020	20A	A002	¾B	D020	20A
J025	25A	A003	1B	D025	25A
J040	40A	A004	1½B	D040	40A
J050	50A	A005	2B	D050	50A
J065	65A	A006	2½B	D065	65A
J080	80A	A007	3B	D080	80A
J100	100A	A008	4B	D100	100A
J125	125A	A009	5B	D125	125A
J150	150A	A010	6B	D150	150A
J200	200A	A011	8B	D200	200A
		XXXX	Other		

3. Glass material

- T** Tempered
O Other

4. Flange rating code

JIS		ANSI		PN	
J010	JIS 10K	A010	ANSI 150 Lb	P010	10 bar
J020	JIS 20K	A020	ANSI 300 Lb	P016	16 bar
XXXX	None	OXXX	Other		

5. Screwed connection

- A** NPT (F)
J PT (F)
N None

6. Gaskets material

- N** Non-asbestos
T Teflon
O Other

7. Body material

- C** Carbon steel (A216 WCB)
4 304SS (A351 CF8)
6 316SS (A351 CF8M)
O Other

1	2	3	4	5	6	7
S200	J025	T	J010	N	T	6

Sample ordering code