

Hermetically sealed case bimetal thermometer with adjustable stem

Model : T191

Spec. sheet no. TD01-10

Service intended

Bimetal thermometer is used for measuring temperature of gas or fluid. This thermometer prevents entry of moisture into the casing, thus minimizing the possibility of icing or fogging inside the case.



Nominal diameter

75, 100, 125 and 150 mm

Accuracy

±2.0 % of full scale

Temperature element

Coiled bimetal

Working range

Maximum scale value

Degree of protection

EN60529/IEC529/IP67 (125 mm)

EN60529/IEC529/IP66 (100 mm)



Standard features

Location of stem

Center back with adjustable stem

Case

Hermetically sealed, 316L SS

Cover

Hermetically sealed, 316L SS

Window

Safety glass

Dial

White aluminium with black graduations

Pointer

Black painted aluminium alloy

Stem

6.0, 6.4, 8.0 and 10.0 mm diameter

304SS, 316SS and 316L SS

Max. Insertion length : 2,000 mm

Zero adjustment

External

Stem, process connection

¼", ⅜", ½", ¾" PT, NPT and PF

Option

±1.0 % of full scale

Window : Safety glass

Special range : 0 ~ 600 °C

WISE[®]

| T191_01

1. Base model

T191 Hermetically sealed case bimetal thermometer with adjustable stem

2. Nominal diameter (mm)

- 3** 75
- 4** 100
- 5** 125
- 6** 150

3. Type of mounting

- Y** Center back with adjustable stem

4. Stem material

- 0** 304SS
- 1** 316SS
- 2** 316L SS

5. Stem, process connection

- A** None
- C** ¼"
- D** ⅜"
- E** ½"
- F** ¾"
- G** 1½S (Only available with sanitary)
- H** 2S (Only available with sanitary)
- I** 2½S (Only available with sanitary)

6. Stem connection type (CF: Compression fitting)

- A** None
- B** PF
- C** PT
- D** NPT
- E** CF + PT
- F** CF + NPT
- G** CF + PF
- H** MT + PT (Movable thread)
- I** MT + NPT (Movable thread)
- J** MT + PF (Movable thread)
- S** Clamp (Sanitary type flange)

7. Stem outer diameter (mm)

- 0** 6.0
- 1** 6.4
- 2** 8.0
- 3** 10.0 (Not available process connection, ¼")

8. Range

XXX Refer to scale range table

9. Insertion length

X Refer to insertion length table

10. Accessories

- 0** None
- 1** Thermowell
- 2** Special accuracy (±1.0 % of full scale)
- 3** Thermowell and special accuracy

1	2	3	4	5	6	7	8	9	10
T191	6	Y	1	F	C	1	XXX	X	1

Sample
ordering code

T191 : Type of mounting

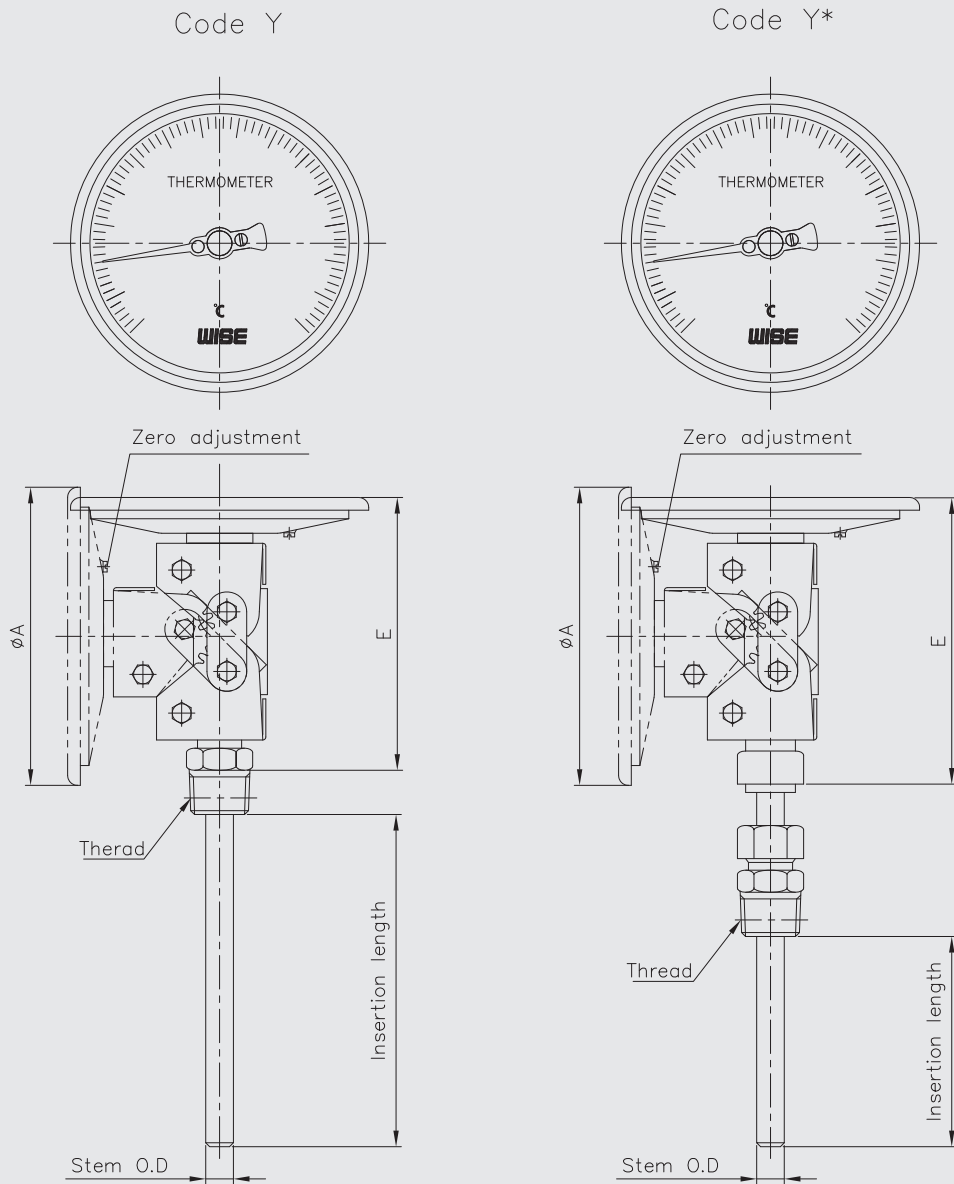

Dimensions (mm)

Dial Size	Available code	A	E
75	Y	86	102
	Y*	86	100
100	Y	110	104.5
	Y*	110	102.5
125	Y	137.2	103.5
	Y*	137.2	101.5
150	Y**	166.2	103
	Y***	166.2	101

Scale ranges

Code	Scale range (°C)	Scale spacing (°C)	Minimum stem length (mm)	
			6.0 and 6.4	8.0 and 10.0
032	-50 ~ 50	2	55	50
037	-50 ~ 100	2	45	35
054	-30 ~ 50	2	70	60
059	-30 ~ 100	2	50	45
061	-30 ~ 120	2	45	35
069	-20 ~ 50	2	80	70
074	-20 ~ 100	2	45	45
079	-20 ~ 150	5	40	35
084	-10 ~ 50	1	95	80
099	0 ~ 50	1	110	70
100	0 ~ 60	1	95	80
101	0 ~ 70	2	80	60
102	0 ~ 80	1	70	55
104	0 ~ 100	2	55	50
106	0 ~ 120	2	50	45
109	0 ~ 150	2	45	35
114	0 ~ 200	5	35	35
119	0 ~ 250	5	35	30
124	0 ~ 300	5	35	25
129	0 ~ 350	5	30	25
134	0 ~ 400	5	80	65
144	0 ~ 500	10	70	60
154	0 ~ 600	10	70	60

Insertion length

Code	1	2	3	4	5	6	7	8	9	A	B	C
Length (mm)	50	60	70	80	100	120	130	150	175	200	225	250

Code	D	E	F	G	H	J	K	L	M	N	P
Length (mm)	275	300	350	375	400	450	500	550	1,000	1,500	2,000