

Euro gauge Direct reading thermometer Model : T250

Spec. sheet no. TD02-11

Service intended

This thermometer is used for measuring temperature of corrosive and non-corrosive fluid in all industries. It operates in aggressive and non-aggressive environment. Linear dials and temperature compensate line assure an accurate temperature indication at varying ambient conditions.



Nominal diameter

100 and 160 mm

Accuracy

±2.0 % of full scale

Measuring system (SAMA class IIIB)

Organic gas : 0 ~ 200 °C
Inert gas : -200 ~ 700 °C

Working range

Maximum scale value



Standard features

Location of stem

Bottom connection, direct
Lower back connection, direct

Case

304SS

Cover

304SS
Bayonet type

Window

Tempered safety glass

Dial

White aluminium with black graduation

Pointer

Black painted aluminium alloy

Stem

8.0, 10.0 and 12.0 mm
316SS and 316L SS

Stem, process connection

3/8", 1/2", 3/4" PT, NPT and PF

Option

Special accuracy, ±1.0 % of full scale

1. Base model

T250 Euro gauge direct reading thermometer

2. Nominal diameter (mm)

- 4 100
- 6 160

3. Type of mounting

- A Bottom connection, direct
- G Lower back connection, direct

4. Stem material

- 1 316SS
- 2 316L SS

5. Stem, process connection

- A None
- D $\frac{3}{8}$ "
- E $\frac{1}{2}$ "
- F $\frac{3}{4}$ "

6. Stem connection type (CF: Compression fitting)

- A None
- E CF + PT
- F CF + NPT
- G CF + PF
- H MT + PT (Movable thread)
- I MT + NPT (Movable thread)
- J MT + PF (Movable thread)

7. Stem outer diameter (mm)

- 2 8.0
- 3 10.0
- 4 12.0
- Z Other

8. Range

XXX Refer to scale range table

9. Insertion length

X Refer to insertion length table

10. Accessories

- 0 None
- 1 Thermowell
- 2 Special accuracy ($\pm 1.0\%$ of full scale)
- 3 Thermowell and special accuracy

1	2	3	4	5	6	7	8	9	10
T250	4	A	1	E	C	3	XXX	X	1

Sample
ordering code

T250 : Type of mounting

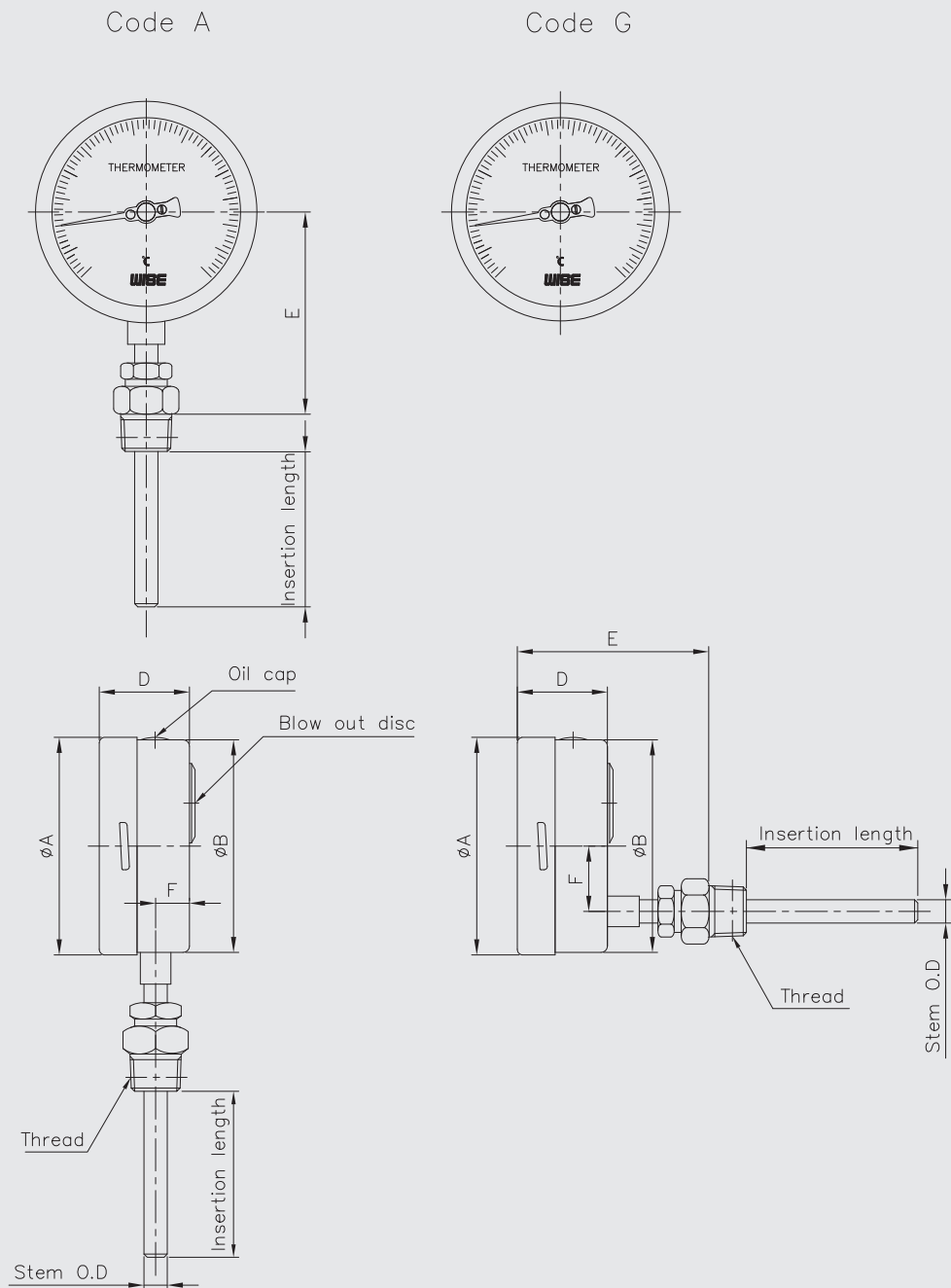

Dimensions (mm)

Dial Size	Available code	A	B	D±2	E±2	F±1
100	A	101.3	99		127	16
	G	101.3	99	136.5	127	16
160	A	160.6	159		155	15.8
	G	160.6	159	136.5	129.5	15.8

Scale ranges

Code	Scale range (°C)	Scale spacing(°C)	Minimum stem length (mm)			Standard stem length (mm)		
			8.0	10.0	12.0	8.0	10.0	12.0
031	-200 ~ 100	5	500	500	500	500	500	500
032	-50 ~ 50	2	100	85	65	200	130	100
037	-50 ~ 100	5	100	88	65	200	130	100
054	-30 ~ 50	2	100	85	65	200	130	100
059	-30 ~ 100	2	100	85	65	200	130	100
061	-30 ~ 120	5	100	85	65	200	130	100
069	-20 ~ 50	2	100	85	65	200	130	100
074	-20 ~ 100	2	100	85	65	200	130	100
079	-20 ~ 150	5	100	85	65	200	130	100
084	-10 ~ 50	1	100	85	65	200	130	100
099	0 ~ 50	1	100	85	65	200	130	100
100	0 ~ 60	1	100	85	65	200	130	100
101	0 ~ 70	2	100	85	65	200	130	100
102	0 ~ 80	2	100	85	65	200	130	100
104	0 ~ 100	2	100	85	65	200	130	100
106	0 ~ 120	2	100	85	65	200	130	100
109	0 ~ 150	5	100	85	65	200	130	100
114	0 ~ 200	5	100	85	65	200	130	100
119	0 ~ 250	5	100	85	65	200	130	100
124	0 ~ 300	5	100	85	65	200	130	100
129	0 ~ 350	5	100	85	65	200	130	100
134	0 ~ 400	10	100	85	65	200	130	100
144	0 ~ 500	10	100	85	65	200	130	100
154	0 ~ 600	10	100	85	65	200	130	100
164	0 ~ 700	10	100	85	65	200	130	100

* 0 ~ 700 °C/Special range

* -200 ~ 100 °C/Special range

Insertion length

Code	1	2	3	4	5	6	7	8	9	A	B	C
Length (mm)	50	60	70	80	100	120	130	150	175	200	225	250

Code	D	E	F	G	H	J	K	L	M	N	P
Length (mm)	275	300	350	375	400	450	500	550	1,000	1,500	2,000