

Euro gauge

Electrical contact type bimetal temperature gauge

Model : T531(H), T532(H/L), T533(L), T534(H/HH), T535(L/LL), T536(H/L)

Spec. sheet no. TD05-04

Service intended

Contact type temperature gauge is installed with electric contact actuated by pointer. It provides the function which electrical circuit can be opened or closed by manual set point. It is applicable where signal is required (Audible or visual alarm) for control of resistance or any other application with auxiliary relay and contact.

Nominal diameter

100 mm

Accuracy

±2.0 % of full scale

Temperature element

Coiled bimetal

Working range

Maximum scale value



Standard features

Location of stem

Bottom connection, surface, case mounting

Case

304SS

Cover

304SS
Bayonet type

Window

Safety glass
Polycarbonate

Dial

White aluminium with black graduation

Contacts

Maximum voltage : 250 V AC
Contact rating : AC 220 V, 0.25 A
DC 100 V, 0.5 A
With max. no of contact : 2 sets per gauge

Pointer

Black painted aluminium alloy

Stem out diameter

6.0, 6.4, 8.0 and 10.0 mm diameter
304SS, 316SS and 316L SS
Max. Insertion length : 2,000 mm

Stem, process connection

$\frac{3}{8}$ ", $\frac{1}{2}$ ", $\frac{3}{4}$ " PT or NPT
G1/2B, G3/4B

Option

Special accuracy, ±1.0 % of full scale

WISE®

1. Base model

- T531** Electrical contact type bimetal temperature gauge (High alarm)
- T532** Electrical contact type bimetal temperature gauge (High and low alarm)
- T533** Electrical contact type bimetal temperature gauge (Low alarm)
- T534** Electrical contact type bimetal temperature gauge (Two high alarm)
- T535** Electrical contact type bimetal temperature gauge (Two low alarm)
- T536** Failsafe high and low alarm

2. Nominal diameter and window material

- 4** 100 mm and safety glass
- 5** 100 mm and polycarbonate window

3. Type of mounting

- A** Bottom connection (Only direct mounting)
- B** Bottom connection, surface, case mounting plate

4. Stem material

- 0** 304SS
- 1** 316SS
- 2** 316L SS

5. Stem, process connection

- D** 3/8"
- E** 1/2"
- F** 3/4"

6. Stem connection type (CF: Compression fitting)

- E** CF + PT
- F** CF + NPT
- G** CF + PF
- H** Clamp (Sanitary type flange)
- I** MT + PT (Movable thread)
- J** MT + NPT (Movable thread)
- S** MT + PF (Movable thread)

7. Stem outer diameter (mm)

- 0** 6.0
- 1** 6.4
- 2** 8.0
- 3** 10.0

8. Range

- XXX** Refer to scale range table

9. Insertion length

- X** Refer to insertion length table

10. Accessories

- 0** None
- 1** Thermowell
- 2** Special accuracy ($\pm 1.0\%$ of full scale)
- 3** Thermowell and special accuracy

1	2	3	4	5	6	7	8	9	10
T531	4	A	1	E	C	3	XXX	X	1

Sample
ordering code

T53X : Type of mounting

Code A

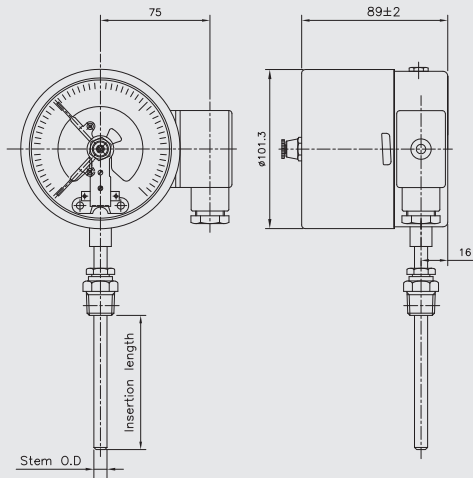

Code B

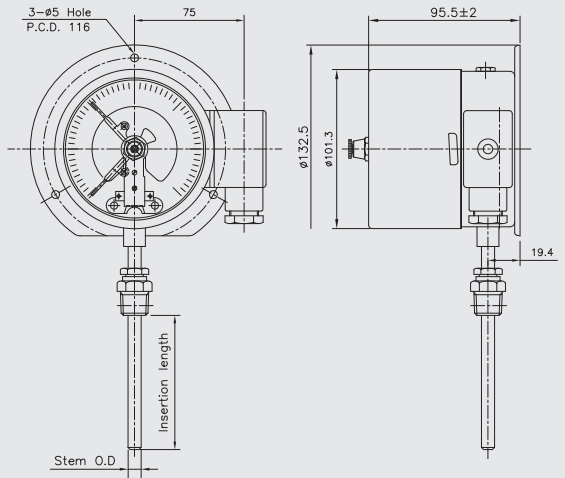

(Safety glass window)

Code A

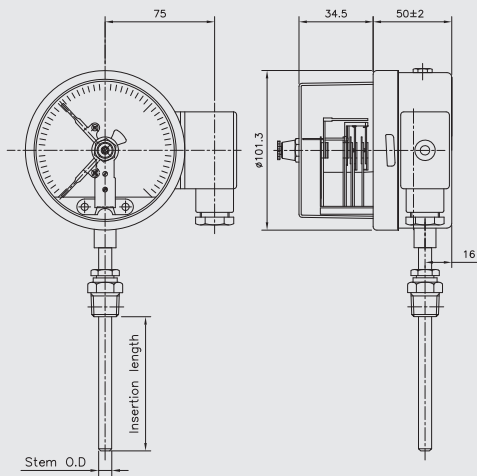

Code B

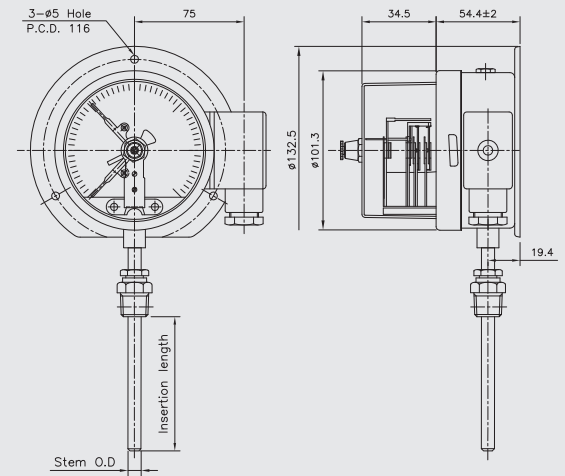

(Polycarbonate window)

Snap - action contacts

General

Electromechanical limit switches in pointer type measuring instruments are auxiliary current switches which open or close electrical circuits at set limit values by means of a contact arm which is moved by the actual value pointer.

The snap action contact is a mechanical contact for switching capacities up to 30 W 50 VA max.

Contact making will be delayed and or advanced in relation to the movement of the actual value pointer.

To closed the circuit, the contact pin of the movable contact arm is attracted in a jump by the permanent magnet fastened to the supporting arm shortly before the set value has been reached.

Due to the retention force of the magnet, snap action contacts are more resistant against shock and vibration.

The switching safety is increased by the increased contact pressure.

When the circuit is opened, the magnet keeps the contact arm in its place until the restoring force of the measuring element exceeds the magnetic force, and the contact opens in a jump.

Specifications

Maximum contact rating with non-inductive (ohmic) load		Electrical contacts type pressure gauge model P510 series	
		Dry gauges	Liquid filled gauges
Maximum voltage		250 V	250 V
Current ratings	Make ratings	1.0 A	1.0 A
	Break ratings	1.0 A	1.0 A
	Continuos load	0.6 A	0.6 A
Maximum load		30 W 50 VA	20 W 20 VA
Material of contact points		Silver-Nickel alloy (80 % Ag / 20 %Ni / 10 µm) gold-plated	
Ambient operating temperature		-20 ...+70 °C	
Max. no. of contacts		2	
Voltage test		Circuit / protective earth conductor - 2,000 vac 1 minute	
		Circuit /circuit - 2,000 vac 1 minute	

Recommended contact ratings with ohmic and inductive load

Voltage (DIN IEC 38) DC / AC	Electrical contacts type pressure gauge model P510 series					
	Dry gauges			Liquid filled gauges		
	Ohmic load		Inductive load	Ohmic load		Inductive load
	DC	AC		DC	AC	
			cosØ > 0.7			cosØ > 0.7
V	mA	mA	mA	mA	mA	mA
220 / 230	100	120	65	65	90	40
110 / 110	200	240	130	130	180	85
48 / 48	300	450	200	190	330	130
24 / 24	400	600	250	250	450	150

In order to ensure a high switching reliability of the contacts the switching voltage should not be below 24 V, also taking environmental influences in the long term into account.

Contact function table

CODE	Wiring Scheme	Contact Function		Wiebrock Code No.	Remark	
		1st Contact	2nd Contact			
Single Contact						
1	Contact make when pointer reachse setpoint (Normal open - NO)				S/M-1	Normal use high alarm system
3	Contact break when pointer reachse setpoint (Normal close - NC)				S/M-2	Normal use low alarm system
Double Contact - Common Circuit						
4	1 st and 2 nd contact make when pointer reaches setpoint				S/M-11	Normal use high and high alarm system
6	1 st contact make 2 nd contact break when pointer reaches setpoint				S/M-12	Normal use failsafe high and low alarm system
2	1 st contact break 2 nd contact make when pointer reaches setpoint				S/M-21	Normal use high and low alarm system
5	1 st and 2 nd contact break when pointer reaches setpoint				S/M-22	Normal use low and low alarm system

Terminal block arrangement

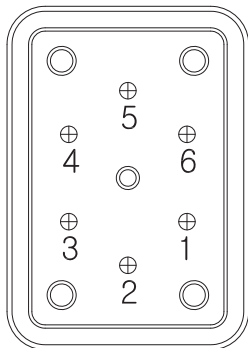

1. High alarm (S/M-1)

- ① Normal open
- ② Common
- ④ Ground

2. High and low alarm (S/M-21)

Low alarm

- ① Normal close
- ② Common
- ④ Ground

High alarm

- ② Common
- ③ Normal open

3. Low alarm (S/M-2)

- ① Normal close
- ② Common
- ④ Ground

4. Two high alarm (S/M-11)

No.1 High alarm

- ① Normal open
- ② Common
- ④ Ground

No.2 High alarm

- ② Common
- ③ Normal open

5. Two low alarm (S/M-22)

No.2 Low alarm

- ① Normal close
- ② Common
- ④ Ground

No.1 Low alarm

- ② Common
- ③ Normal close

6. Failsafe high and low alarm (S/M-12)

High alarm

- ② Common
- ③ Normal close
- ④ Ground

Low alarm

- ① Normal open
- ② Common

Scale ranges

Code	Scale range (°C)	Scale spacing(°C)	Minimum stem length (mm)	
			6.0 and 6.4	8.0 and 10.0
032	-50 ~ 50	2	55	50
037	-50 ~ 100	5	45	35
054	-30 ~ 50	2	70	60
059	-30 ~ 100	2	50	45
061	-30 ~ 120	5	45	35
069	-20 ~ 50	2	80	70
074	-20 ~ 100	2	45	45
079	-20 ~ 150	5	40	35
084	-10 ~ 50	1	95	80
099	0 ~ 50	1	110	70
100	0 ~ 60	1	95	80
101	0 ~ 70	2	80	60
102	0 ~ 80	2	70	55
104	0 ~ 100	2	55	50
106	0 ~ 120	2	50	45
109	0 ~ 150	5	45	35
114	0 ~ 200	5	35	35
119	0 ~ 250	5	35	30
124	0 ~ 300	5	35	25
129	0 ~ 350	5	30	25
134	0 ~ 400	5	80	65
144	0 ~ 500	10	70	60
154	0 ~ 600	10	70	60

Insertion length

Code	1	2	3	4	5	6	7	8	9	A	B	C
Length (mm)	50	60	70	80	100	120	130	150	175	200	225	250

Code	D	E	F	G	H	J	K	L	M	N	P
Length (mm)	275	300	350	375	400	450	500	550	1,000	1,500	2,000