

Ultrasonic liquid flow meter

Clamp-on type

Model : U100 Series

Spec. sheet no. UD01-01

Description

WISE aquasonic U100 series clamp-on ultrasonic transit time flow meters are highly accurate, compact and economic flow measurement instruments. These are used for all pipes and fluids that can be penetrated by ultrasonic wave. WISE aquasonic measuring method is non-intrusive with no moving parts so it has no pressure drop and energy loss.



Advantages

- 1 % accuracy clamp-on liquid flowmeter for industrial applications
- Easy and quick installation
- Temperature compensation
- Wide turn-down ratio over 100:1
- No flow-stop for Zero-calibration
- Versatile external input / output interfaces
- One time calibration
- Minimal maintenance

Specification

Fluid

Ultrasonically conductive fluids
Pure water, Clean water
Waste water, Industrial water
River and sea water, etc.

Fluid temperature range

-40 ~ +160 °C

Measurement method

Correlation transit time

Pipe size

DN15 ~ DN6000

Range

0.2 ~ 15 m/s

Accuracy

1 % for greater than 0.3 m/s

Non-linearity

±0.1 %

Repeatability

±0.25 %

Protection class

Weather proof (IP65)

Display

2 Line x 16 character LCD with Backlight

Keypad

4 keypad buttons

Power supply

AC 85 ~ 260 V / DC 24 V (Option)
Less than 15 W

Output

DC 4 ~ 20 mA
RS-485
Pulse (Option)

1. Base model**U100** Ultrasonic liquid flow meter clamp-on type**2. Sensor**

- S** Small size 10 ~ 100 mm Pipe
- M** Middle size 50 ~ 700 mm Pipe
- L** Large size 300 ~ 6000 mm Pipe

3. Power

- 1** AC 85 ~ 260 V
- 2** DC 24 V

4. Output

- 1** DC 4 ~ 20 mA, RS-485
- 2** DC 4 ~ 20 mA, RS-485, Pulse

5. Mounting

- 1** Wall mount
- 2** Pipe mount

6. Signal cable (m)

- 1** 10
- 2** 20
- 3** 30

1	2	3	4	5	6
U	M	1	2	1	1

Sample ordering code

Electrical connection

Transmitter

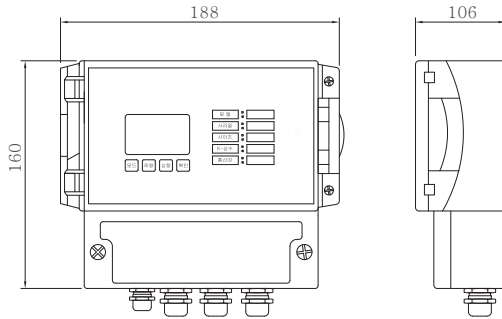

Sensor

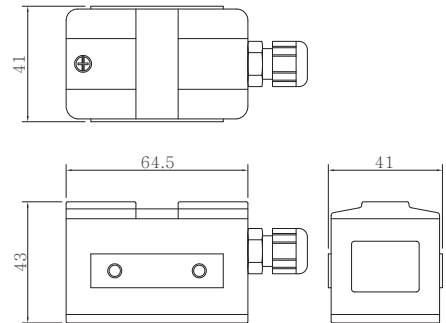

Install

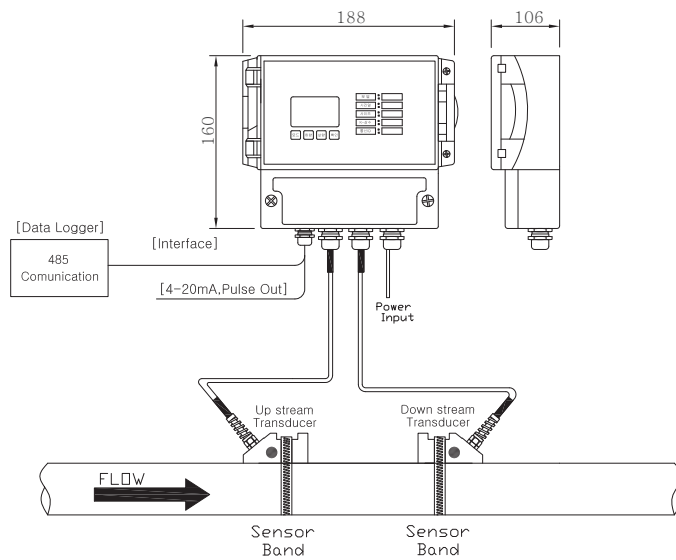

Wiring

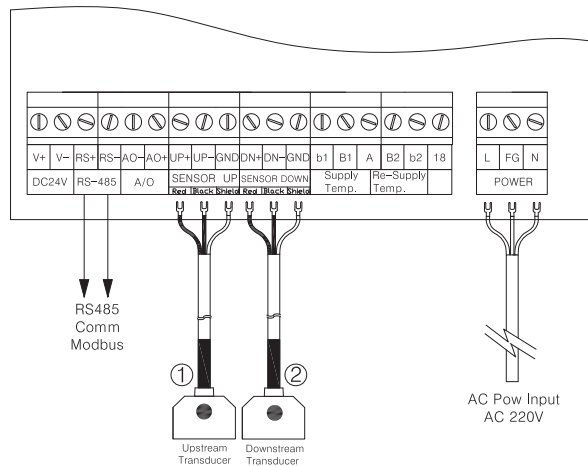

Large empty rectangular area for writing the memo content.