

Direct reading thermometer with aluminium case

Model : T222

Spec. sheet no. TD02-06

Service intended

This thermometer is used for measuring temperature of corrosive and non-corrosive fluid in all industries. It operates in aggressive and non-aggressive environment. Linear dials and temperature compensate line assure an accurate temperature indication at varying ambient conditions.



Nominal diameter

100 and 150 mm

Accuracy

±2.0% of full scale

Measuring system (SAMA class IIIB)

Organic gas : 0 ~ 200°C

Inert gas : -200 ~ 700°C



Working range

Maximum scale value

Standard features

Location of stem

Bottom connection, direct
Bottom connection, surface, case mounting
Lower back connection, direct

Case

Black finished aluminium

Cover

Black finished aluminium

Window

Glass

Dial

White aluminium with black graduation

Pointer

Black painted aluminium alloy

Stem

8.0, 10.0 and 12.0 mm
316SS and 316L SS

Zero adjustment

Internal

Stem, process connection

3/8", 1/2", 3/4" PT, NPT and PF

Optional

±1.0% of full scale

1. Base model

T222 Direct reading thermometer with aluminium case

2. Nominal diameter (mm)

- 4 100
- 6 150

3. Type of mounting

- A Bottom connection, direct
- B Bottom connection, surface, case mounting
- G Lower back connection, direct

4. Stem material

- 1 316SS
- 2 316L SS

5. Stem, process connection

- A None
- D 3/8"
- E 1/2"
- F 3/4"

6. Stem connection type (CF: Compression fitting)

- A None
- B PF
- C PT
- D NPT
- E CF + PT
- F CF + NPT
- G CF + PF
- H MT + PT (Movable thread)
- I MT + NPT (Movable thread)
- J MT + PF (Movable thread)

7. Stem outer diameter (mm)

- 2 8.0
- 3 10.0
- 4 12.0

8. Range

XXX Refer to scale range table

9. Insertion length

X Refer to insertion length table

10. Accessories

- 0 None
- 1 Thermowell
- 2 Special accuracy (±1.0% of full scale)
- 3 Thermowell and special accuracy

1	2	3	4	5	6	7	8	9	10
T222	4	A	1	E	C	3	XXX	X	1

Sample ordering code

T222 : Type of mounting

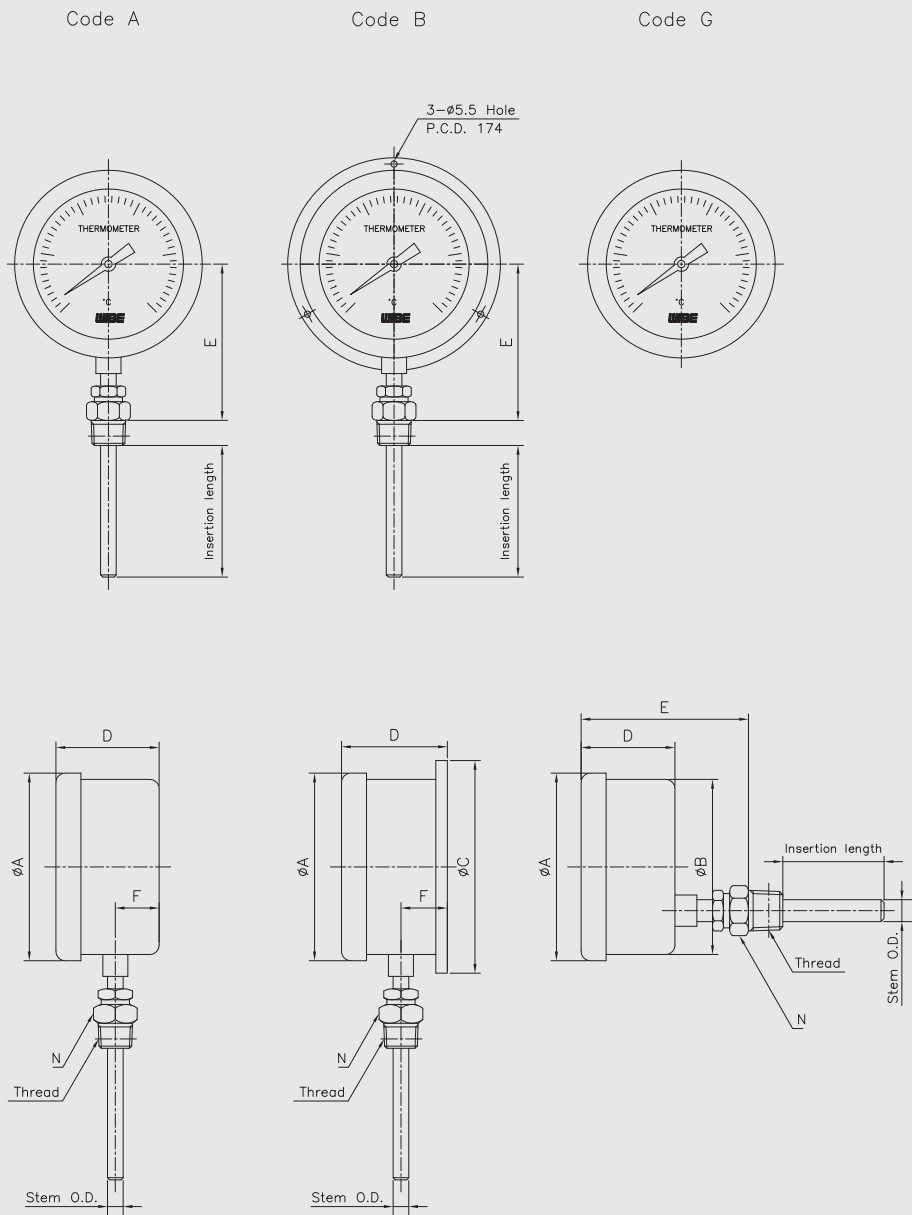

Dimensions (mm)

Dial Size	Available code	A	B	C	D ± 2	E ± 2	F ± 1	N
100	A	110			52	100	20.5	27x31.2 HEX
	B	110		128	52	112	20.5	27x31.2 HEX
	G	110	105		52	112	25	27x31.2 HEX
150	B	172		185	64	150	19.5	27x31.2 HEX
	G	172	159		64	124	25	27x31.2 HEX

Scale ranges

Code	Scale range (°C)	Scale spacing (°C)	Minimum stem length (mm)		
			8.0	10.0	12.0
031	-200 ~ 100	5	150	100	65
032	-50 ~ 50	2	100	85	65
037	-50 ~ 100	2	100	85	65
054	-30 ~ 50	2	100	88	65
059	-30 ~ 100	5	100	85	65
061	-30 ~ 120	2	100	85	65
069	-20 ~ 50	2	100	85	65
074	-20 ~ 100	2	100	85	65
079	-20 ~ 150	2	100	85	65
084	-10 ~ 50	1	100	85	65
099	0 ~ 50	1	100	85	65
100	0 ~ 60	1	100	85	65
101	0 ~ 70	2	100	85	65
102	0 ~ 80	1	100	85	65
104	0 ~ 100	2	100	85	65
106	0 ~ 120	2	100	85	65
109	0 ~ 150	2	100	85	65
114	0 ~ 200	5	100	85	65
119	0 ~ 250	5	100	85	65
124	0 ~ 300	5	100	45	40
129	0 ~ 350	5	100	45	40
134	0 ~ 400	5	100	45	40
144	0 ~ 500	10	100	45	40
154	0 ~ 600	10	100	45	40
164	0 ~ 700	10	100	45	40

* 0 ~ 700°C/Special range

* -200 ~ 100°C/Special range

Insertion length

Code	1	2	3	4	5	6	7	8	9	A	B	C
Length (mm)	50	60	70	80	100	120	130	150	175	200	225	250

Code	D	E	F	G	H	J	K	L	M	N	P
Length (mm)	275	300	350	375	400	450	500	550	1,000	1,500	2,000